

 **Beta** *Action*



2020

Promotion valid until **14/12/2020**

Beta

RSC55



360°
view

*Configure
your workshop
on-line*



www.rsc55.it



C55AP

WORKBENCH, FOR WORKSHOP EQUIPMENT COMBINATION COMPRISED OF:

C55B

Bench with worktop (2050x700 mm) covered with a shockproof, non-scratch ABS coat resistant to oil and hydrocarbons.

Fitted with:

- Holes for a vice (1599F/150, to be ordered separately)
- Vertically adjustable feet

C55M4

Fixed module with 4 drawers 588x367 mm, with ball bearing slides

- Aluminium opening system throughout length of drawer
- Drawer bases protected by foamed rubber mats
- Front centralized lock
- Can be fitted with foam trays

C55T3

Trolley with 3 tops covered in antislip ribbed rubber

- Ergonomic handle
- Two fixing options for central worktop
- 4 castors Ø 100 mm, 2 fixed, and 2 steering with brakes
- Static load capacity: 200 kg

C55PSP

Tool wall system with shutter and framework

- Aluminium shutter, vertically adjustable, with lock
- Removable perforated panel for holding tools

C55AC

Self-supporting complete corner

- Worktop (700x700 mm) with legs
- 2 upper tool wall systems complete with 2 fixing shelves (670x160 mm)

C55B/1

1-m-long extension

- Worktop (1024x700 mm) covered with a shockproof, non-scratch PVC coat resistant to oil and hydrocarbons
- Universal leg with vertically adjustable feet
- Fixed module with 7 drawers (588x367 mm) with ball bearing slides
- Self-supporting perforated panel (1024 x 1000 mm) for holding tools

New item



055000030 498 kg



9562P2

Multilogo mat, 200x80 cm

- Particularly suitable for use with workshop equipment item C55 or under motorcycles

095620400 1,6 kg

New item



RSC 55

WORKBENCH, FOR WORKSHOP EQUIPMENT COMBINATION COMPRISED OF:

C55PRO B0/2

- Bench with worktop**
(2050x700 mm) covered with a shockproof, non-scratch ABS coat resistant to oil and hydrocarbons
- Holes for a vice (1599F/150, to be ordered separately)
 - Vertically adjustable feet

C55C7

- Mobile roller cab with seven drawers** 588x367 mm, with ball bearing slides
- 4 castors Ø 100 mm, 2 fixed (one with brake) and 2 steering
 - Drawer bases protected by foamed rubber mats
 - Front centralized lock

C55M7

- Fixed module with seven drawers** 588x367 mm, with ball bearing slides
- Drawer bases protected by foamed rubber mats
 - Front centralized lock

C55PB-PRO/5

- Workbench with tool wall system**
Supplied with framework
- Aluminium shutter, vertically adjustable, with lock
 - Removable perforated panel for holding tools

055000025 346 kg



C55PB-PRO/5E

- Workbench with tool wall system with shutter accommodating 2 power sockets** (not included)
- Aluminium shutter, vertically adjustable, with lock
 - Removable perforated panel for holding tools
 - Supplied with framework

055000026 346 kg

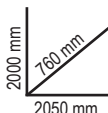
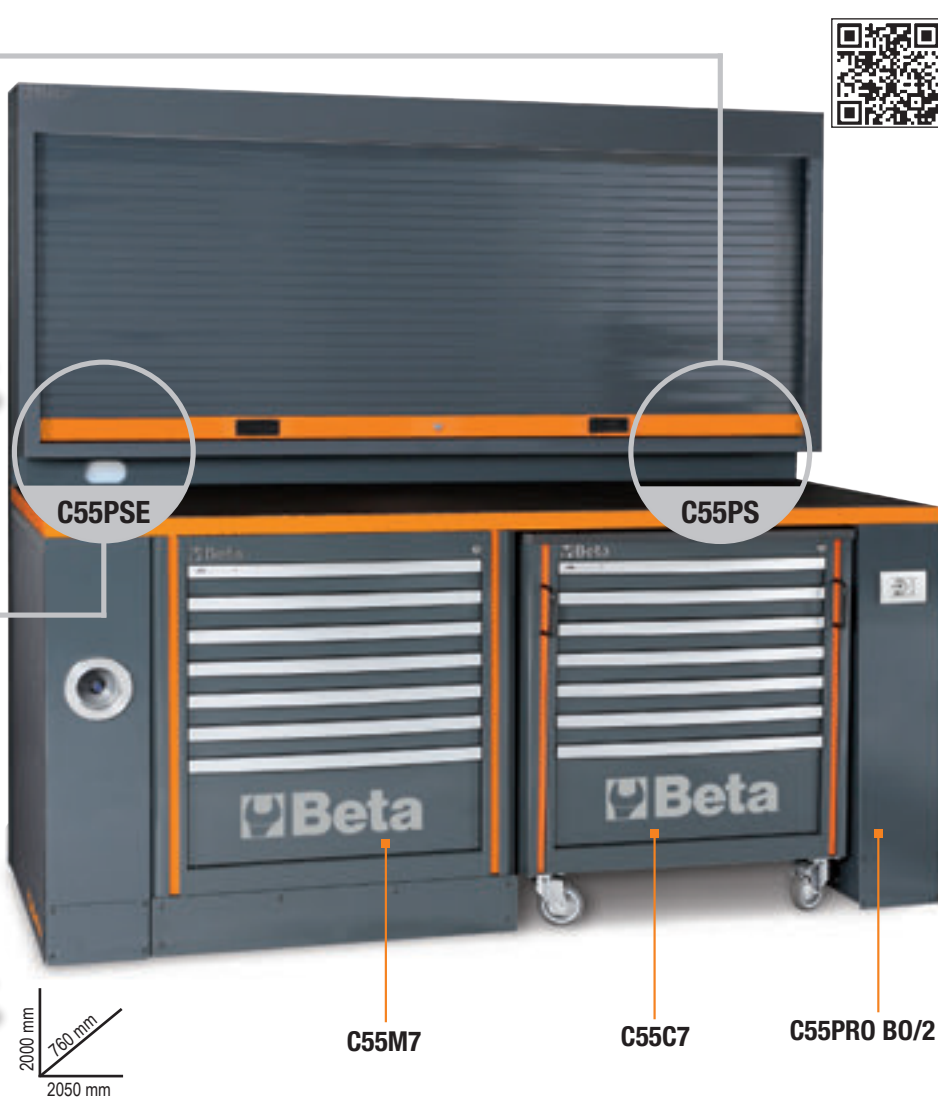

Can be fitted with foam trays of the Beta range



Schuko socket +16+10A
EU Plug 16+10A



The steering wheels allow mobile roller cab C55C7 to be easily pulled out



Compressed air outlet and roller Ø 8 mm.
Length: 10 m





C37

Mobile roller cab

Main features:

- Sturdy multi-purpose worktop
- Quick release system made of aluminium, opening throughout length of drawer
- **Corner bumpers** throughout height of roller cab, to avoid damaging vehicles in garage
- Four castors Ø 125 mm:
2 fixed and 2 steering (one with brake)
- Tote-trays and holes for accommodating screwdrivers
- Built-in side bottle and paper holders, adjustable in several positions



New item

Kg
1000



C37/6	037000061	037000062	037000063	
C37/7	037000071	037000072	037000073	
C37/8	037000081	037000082	037000083	



C37A/7

Mobile roller cab with 7 drawers
With anti-tilt system

New item



Anti-tilt system



C37A/7	037000271	037000272	037000273	
---------------	------------------	------------------	------------------	--



C37

New item

3700/PLA

Stainless steel worktop



037000100

2,8 kg

672x396x1,5 mm

3700/PLL

Wood worktop



037000101

3,9 kg

672x396x28 mm

3700/PF

Perforated panel with brackets



650x626x80 mm

037000102

3,2 kg

3700/PFL

Perforated side panel



754x321x38 mm

037000104

1,9 kg

3700/PC

Computer bracket



418x303x399 mm

037000103

3,1 kg

C39

Aluminium^{AL}

Mobile roller cab

- Four castors with steel cores, Ø 125 mm: 2 fixed and 2 steering (one with brake)
- Front centralized safety lock

Uprights and drawer front made of aluminium alloy + STURDINESS + LIGHTWEIGHTNESS

Built-in side and rear bottle and paper holders.



Sturdy multi-purpose worktop with tote-trays and holes for accommodating screwdrivers



Pull-out drawer with opening system throughout its length



C39/6	039000031	039000032	039000033	
C39/7	039000001	039000002	039000003	
C39/8	039000041	039000042	039000043	





C24S

Mobile roller cab

- Four castors with steel cores, Ø 125 mm: 2 fixed and 2 steering (one with brake)
- Front centralized safety lock
- Can accommodate paper roll holder item 2400S-R/PC, to be ordered separately



Pull-out drawer with quick release system made of fibreglass-reinforced nylon, opening throughout length of drawer



Sturdy ABS worktop

Built-in side bottle holder



C24S/6	024002061	024002062	024002063			
C24S/7	024002071	024002072	024002073	024002076	024002079	
C24S/8	024002081	024002082	024002083			



C24SA-XL

Mobile roller cab with anti-tilt system, long model

- Four castors with steel cores, Ø 125 mm: 2 fixed and 2 steering (one with brake)
- Front centralized lock
- Can accommodate paper roll holder item 2400S-R/PC, to be ordered separately

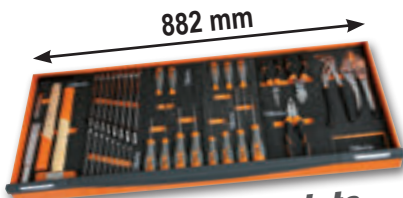

Can accommodate up to 6 thermoformed trays in one drawer

ABS worktop, with 6 tote-trays

Sturdy nylon front, with built-in label holder

Built-in side bottle holder



C24SA-XL/7	024002271	024002272	024002273		
C24SA-XL/8	024002281	024002282	024002283		
C24SA-XL/9	024002331	024002332	024002333		



Anti-tilt system

C24SL-CAB

Mobile roller cab with 7 drawers and tool cabinet

- Four castors with steel cores, Ø 125 mm:
2 fixed and 2 steering (one with brake)
- Front centralized lock

Multi-ply wood worktop with holes for a vice
(1599F/100, to be ordered separately)



Side cabinet with vertically adjustable interior top and lockable door



Built-in paper roll holder
Double rear bottle holder



C24SL-CAB

024002191

024002192

024002193



C24SL

Mobile roller cab with 7 drawers and side tops

7 drawers (588x367 mm) with ball bearing slides:

5 drawers, 70 mm high

1 drawer, 140 mm high

1 drawer, 210 mm high

- Drawer bases protected by foamed rubber mats
- Four castors 125 mm in Ø:
2 fixed and 2 steering (two with brakes)
- Front centralized safety lock
- Side compartment with vertically adjustable top
- Integrated paper roll holder
- Double rear bottle holder

Multi-ply wood worktop
with holes for a vice
(1599F/100, to be ordered separately)



C24SL

024002101

024002102

024002103





C28

SuperTank trolley with worktop and 10 drawers

- 5 side drawers
- 5 front drawers
- Drawer bases protected by foamed rubber mats
- 4 high-capacity castors 150 mm in Ø:
2 fixed and 2 steering (with brakes)
- 2 centralised safety locks

Multiply wood worktop with holes for a vice (1599F/150, to be ordered separately)

n°	h	max.
8	70 mm	25 kg
2	210 mm	30 kg



Quick, safe system for opening and closing drawers, with nylon and fibreglass front



35-mm-high storage compartment with plastic-covered base

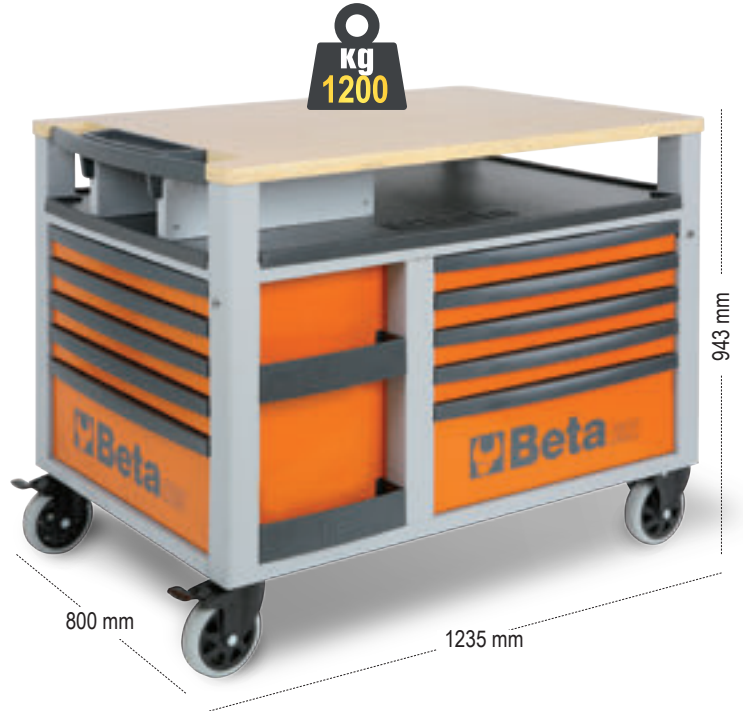

130 kg



C28 028000301 028000302 028000303



New item

2400-COVER C24S

Nylon cover for
• C24S
• C24SA
• C39



024000910

2400-COVER C24SA-XL

Nylon cover for
• C24SA/XL
• C24SL
• C24SL-CAB



024000930

3700-COVER C37

Nylon cover for
• C37



037000930

4100-COVER C41H

Nylon cover for
• C41H



041000930

C54S

Cargo tool cabinets

These tool cabinets are designed according to detailed research and offer accurate, comfortable and rational solutions for end users. Two perforated panels attached to the doors may be opened giving access to additional storage space.

Main features:

- 1 drawer, with slides
- Easy tool layout according to users' needs
- Easy wall mounting by means of two slots located at the back of the cabinet
- Safety lock for both drawers and doors
- Empty thermoformed tray for 1/2" sockets and accessories



New item



1555 mm



37 kg

C54S

054000301

054000302

054000303



C04TSS/7

Mobile roller cab with seven drawers, made of stainless steel

- Four castors with steel cores, Ø 125 mm: 2 fixed and 2 steering (with brakes);
- Front centralized lock;
- Frame made entirely of stainless steel
- Castors, supports, ball bearings, drawer interiors and guides made of stainless steel
- Drawer handles made of aluminium

Other inox products pages 16 - 22 - 25 - 30 - 37



Non-marking wheels

n°	h	max.
6	83 mm	25 kg
1	170 mm	30 kg



024003077

63 kg



5988U6/MP

Assortment of 214 tools
in soft foam tray



Recommended for use in combination with mobile roller cabs:
C24S-C24SL-C37-C39-C28-C24SLCAB-C59-RSC55

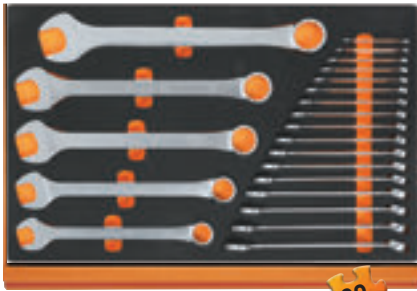

M10



M30

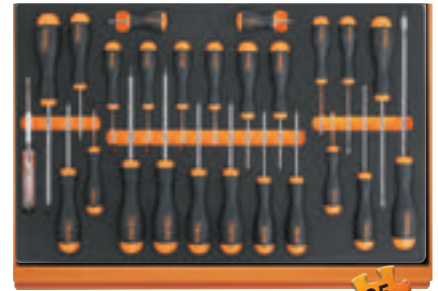

M210



M230



M130

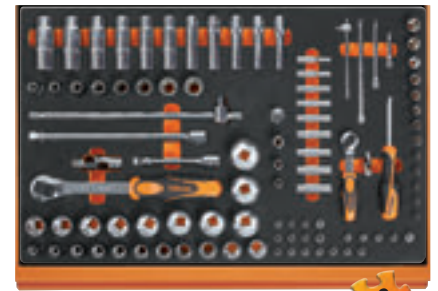

M100



N. Quantity/Description

- 22 combination wrenches 6-7-8-9-10-11-12-13-14-15-16-17-18-19-20-21-22-24-27-30-32-36 mm
- 11 double open end wrenches 6x7-8x9-10x11-12x13-14x15-16x17-18x19-20x22-21x23-24x27-30x32 mm
- 11 double ended offset ring wrenches 6x7-8x9-10x11-12x13-14x15-16x17-18x19-20x22-21x23-24x27-30x32 mm
- 9 ball head offset hexagon key wrenches
Ø 1,5-2-2,5-3-4-5-6-8-10 mm
- 6 screwdrivers for cross head Phillips® screws
● 2,5x50-3x75-4x100-5,5x125-6,5x150-8x200 mm
- 1 screwdrivers for slotted head screws, extra-short series
● 4x30 mm
- 4 screwdrivers for cross head Phillips® screws
● PH0x60-PH1x80-PH2x100-PH3x150 mm
- 1 screwdrivers for cross head Phillips® screws, extra-short series
● PH1x30 mm
- 12 drivers for Torx® head screws, with handles
● T6-T7-T8-T9-T10-T15-T20-T25-T27-T30-T40-T45
- 1 mains testing screwdriver ●
- 3 drift punches Ø 2-3-4 mm
- 6 pin punches Ø 2-3-4-5-6-8 mm
- 1 centre punch Ø 4 mm
- 1 flat chisels 150 mm
- 2 flat chisels, ribbed type 200-250 mm
- 1 cape chisels, standard type 125 mm
- 1 engineer's hammer 500 g
- 1 soft face hammer Ø 35 mm
- 1 measuring tape 3 m
- 1 telescopic magnet with flexible head
- 1 second-cut square files 200 mm
- 1 second-cut triangular files 200 mm
- 1 second-cut flat files 200 mm
- 1 second-cut half-round files 200 mm
- 1 second-cut round files 200 mm
- 1 brake shoe cleaning brush plastic handle steel wires
- 1 snap - off blade utility knife 18 mm

Beta N.	TR
42	M10
55	M30
90	M30
96BPC/SC9	M30
1201	M210
1201N	M210
1202	M210
1202N	M210
1207TX	M210
1253	M210
30	M230
31	M230
32	M230
34	M230
35	M230
36	M230
1370	M230
1390	M230
1692	M230
1712TF	M230
1719BMA...Q	M230
1719BMA...T	M230
1719BMA...P	M230
1719BMA...M	M230
1719BMA...R	M230
1737NX	M230
1771	M230

N. Quantity/Description

- 1 circlip pliers straight, internal ○ 180 mm
- 1 circlip pliers bent, internal ○ 170 mm
- 1 circlip pliers straight, external ● 175 mm
- 1 circlip pliers bent, external ● 175 mm
- 1 slip joint pliers boxed joints 250 mm
- 1 self - locking pliers 240 mm
- 1 diagonal cutting nippers 160 mm
- 1 construction worker's pincers 220 mm
- 1 tin snips 250 mm
- 1 electrician's scissors, straight blades
- 1 half-round needle nose pliers 180 mm
- 1 extra long needle knurled nose pliers, bi-material handles
● 160 mm
- 1 bent needle nose pliers ● 160 mm
- 1 socket holder
- 1 socket holder
- 1 socket holder
- 13 1/4" hexagon sockets ○ 4-4,5-5-5,5-6-7-8-9-10-11-12-13-14 mm
- 9 hexagon hand sockets, long series ○ 5-6-7-8-9-10-11-12-13 mm
- 5 1/4" socket drivers for hexagon screws ○ 3-4-5-6-7 mm
- 4 socket drivers for slotted head screws
● 0,8x4-1x5,5-1,2x6,5-1,2x8 mm
- 4 socket drivers for cross head Phillips® screws
● PH1-PH2-PH3-PH4
- 7 socket drivers for Torx® head screws
● T10-T15-T20-T25-T27-T30-T40
- 1 1/4" drive extension bar 50 mm
- 1 1/4" drive extension bar 100 mm
- 1 1/4" drive extension bar 150 mm
- 1 1/4" drive universal joint
- 1 1/4" drive spinner handle
- 1 1/4" drive swivel T-handle
- 1 1/4" reversible ratchet ⊕
- 21 1/2" square drive hexagon sockets ○ 8-10-11-12-13-14-15-16-17-18-19-20-21-22-23-24-26-27-28-30-32 mm
- 1 adaptor, 1/2" female and 3/8" male drives 125 mm
- 1 1/2" drive universal joint 250 mm
- 1 1/2" wobble extension bar
- 1 1/2" wobble extension bar
- 1 1/2" drive sliding T-handle
- 1 1/2" drive reversible ratchet ⊕
- 8 1/2" sockets for Torx® head screws
● 10-12-14-16-18-20-22-24 mm
- 11 hexagon hand sockets ○ 10-12-13-14-15-16-17-18-19-21-22 mm

Beta N.	TR
1032	M130
1034	M130
1036	M130
1038	M130
1048	M130
1052	M130
1082BM	M130
1098	M130
1112	M130
1128BM	M130
1150BM	M130
1166BM	M130
1168BM	M130
895/1	M100
895/3	M100
895/6	M100
900	M100
900L	M100
900ME	M100
900LP	M100
900PH	M100
900TX	M100
900/20	M100
900/20L	M100
900/21	M100
900/25	M100
900B/30	M100
900/42	M100
900/55	M100
920A	M100
920/15	M100
920/25	M100
920AN/125	M100
920AN/250	M100
920/42	M100
920/55	M100
920FTX	M100
920AL	M100

059880535 24 kg



5904U/MP



Assortment of 91 tools
in soft foam tray

Recommended for use in combination with mobile roller cabs:
C24S-C24SL-C37-C39-C28-C24SLCAB-C59-RSC55



N. Quantity/Description

- 16 combination wrenches 6÷21 mm
- 8 double open end wrenches 6x7 - 8x9 - 10x11 - 12x13 - 14x15 - 16x17 - 18x19 - 20x22 mm
- 9 offset hexagon key wrenches
O 1,5 - 2 - 2,5 - 3 - 4 - 5 - 6 - 8 - 10 mm
- 7 screwdrivers for cross head Phillips® screws ● 2,5x50 - 3x75 - 3,5x100 - 4x125 - 5,5x100 - 5,5x150 - 6,5x150 mm
- 6 screwdrivers for cross head Phillips® screws ⊕ PH0x60 - PH0x100 - PH1x80 - PH1x120 - PH2x100 - PH2x150 mm
- 8 offset hexagon key wrenches O 2-2,5-3-4-5-6-7-8 mm
- 1 1/2" wobble extension bar 125 mm
- 1 1/2" wobble extension bar 250 mm
- 1 1/2" drive universal joint
- 1 1/2" drive sliding T-handle

Beta N.	TR
42	M15
55	M33
96/SC9	M33
1260	M199
1262	M202
96T	M50
920AN/125	M83
920AN/250	M83
920/25	M83
920/42	M83

N. Quantity/Description

- 1 1/2" drive reversible ratchet ⊗
- 19 1/2" square drive hexagon sockets
O 10÷24 - 26 - 27 - 30 - 32 mm
- 1 heavy duty diagonal cutting nippers ⚡ 160 mm
- 1 half-round needle nose pliers ≡ 180 mm
- 1 screwdrivers for slotted head screws ● 160 mm
- 1 Slip joint pliers boxed joints 250 mm
- 1 self - locking pliers 240 mm
- 2 flat chisels, ribbed type 100 - 200 mm
- 1 engineer's hammer 300 g
- 1 soft face hammer Ø 35 mm
- 1 circlip pliers straight, internal O 180 mm
- 1 circlip pliers bent, internal O 170 mm
- 1 circlip pliers straight, external ● 175 mm
- 1 circlip pliers bent, external ● 175 mm

Beta N.	TR
920/55	M83
920A	M83
1084	M132
1150	M132
1166	M132
1048	M153
1052	M153
35	M234
1370	M234
1390	M234
1032	M145
1034	M145
1036	M145
1038	M145

059040425 12 kg



5904VA/T



Assortment of 102 tools
in foam trays

Recommended for use in combination with mobile roller cabs:
C24S-C24SL-C37-C39-C28-C24SLCAB-C59-RSC55

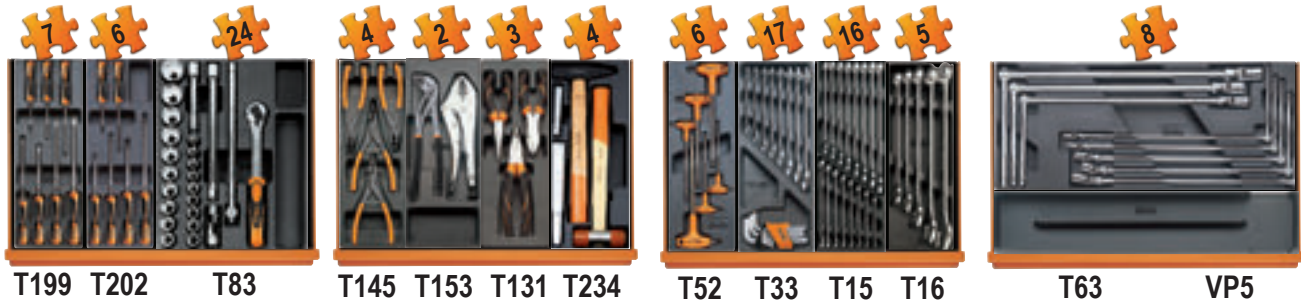

N. Quantity/Description

- 21 combination wrenches 6-7-8-9-10-11-12-13-14-15-16-17 - 18-19-20-21-22-24-27-30-32 mm
- 8 double open end wrenches
6x7-8x9-10x11-12x13-14x15-16x17-18x19-20x22 mm
- 9 offset hexagon key wrenches O 1,5÷10 mm
- 6 offset hexagon key wrenches O 2-2,5-3-4-5-6 mm
- 8 T - handle wrenches with swivelling socket
O 7-8-10-12-13-14-17-19 mm
- 19 1/2" square drive hexagon sockets O 10-11-12-13-14-15-16-17-18-19-20-21-22-23-24-26-27-30-32 mm
- 1 1/2" drive extension bar 125 mm
- 1 1/2" drive extension bar 255 mm
- 1 1/2" drive universal joint
- 1 1/2" drive sliding T-handle 305 mm
- 1 1/2" drive reversible ratchet

Beta N.	TR
42	T15
55	+T16 T33
96/SC9	T33
96T	T52
952	T63
920A	T83
920/21	T83
920/22	T83
920/25	T83
920/42	T83
920/55	T83

N. Quantity/Description

- 1 heavy duty diagonal cutting nippers ⚡ 160 mm
- 1 half-round needle nose pliers ≡ 180 mm
- 1 extra long needle knurled nose pliers, bi-material handles
● 160 mm
- 1 circlip pliers straight, internal O 180 mm
- 1 circlip pliers bent, internal O 170 mm
- 1 circlip pliers straight, external ● 175 mm
- 1 circlip pliers bent, externa ● 175 mm
- 1 self - locking pliers 240 mm
- 1 slip joint pliers boxed jointsa 250 mm
- 7 screwdrivers for cross head Phillips® screws ● 2,5x50 -3x75 - 3,5x100 - 4x125 -5,5x100 - 5,5x150 - 6,5x150 mm
- 6 screwdrivers for cross head Phillips® screws ⊕ PH0x60 - PH0x100 - PH1x80 - PH1x120 - PH2x100 - PH2x150 mm
- 2 flat chisels, ribbed type 100-200 mm
- 1 engineer's hammer 300 g
- 1 soft face hammer Ø 35 mm
- 1 empty thermoformed tray

Beta N.	TR
1084BM	T131
1150BM	T131
1166BM	T131
1032	T145
1034	T145
1036	T145
1038	T145
1052	T153
1048	T153
1260	T199
35	T234
1370	T234
1390	T234
VP5	

059040415 17 kg



M10

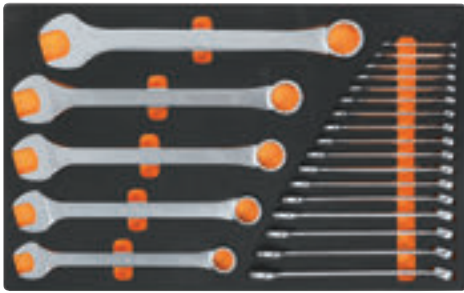

42 6-7-8-9-10-11-12-13-14-15-16-17-18-19-20-21-22-24-27-30-32-36 mm

024500010 4,5 kg

M30



55 6x7-8x9-10x11-12x13-14x15-16x17-18x19-20x22-21x23-24x27-30x32 mm
90 6x7-8x9-10x11-12x13-14x15-16x17-18x19-20x22-21x23-24x27-30x32 mm
96BPC/SC9 1,5-2-2,5-3-4-5-6-8-10 mm

024500030 4,2 kg

M60



○ 96T 2-2,5-3-4-5-6-7-8-10 mm
○ 97BTX/SC8 T9-T10-T15-T20-T25-T27-T30-T40
○ 944BX 5-6-7-8-10-13 mm

024500060 1,9 kg

M63



○ 952 7-8-10-12-13-14-17-19 mm

024500063 3,4 kg

M100

12" 14"



895/1 - 895/3 - 895/6
○ 900 4-4,5-5-5,5-6-7-8-9-10-11-12-13-14 mm
○ 900L 5-6-7-8-9-10-11-12-13 mm
○ 900ME 3-4-5-6-7 mm
● 900LP 0,8x4-1x5,5-1,2x6,5-1,2x8 mm
● 900PH PH1-PH2-PH3-PH4
○ 900TX T10-T15-T20-T25-T27-T30-T40
900/20 50 mm - 900/20L 100 mm
900/21 150 mm
900/25 - 900BG/30 - 900/42
● 900/55
○ 920A 8-10-11-12-13-14-15-16-17-18-19-20-21-22-23-24-26-27-28-30-32 mm
920/15 - 920/25
920AN/125 125 mm
920AN/250 250 mm
920/42
● 920/55
● 920FTX 10-12-14-16-18-20-22-24 mm
○ 920AL 10-12-13-14-15-16-17-18-19-21-22 mm

024500100 6,7 kg

M105

12" 14" 3/8"



○ 900 4-4,5-5-5,5-6-7-8-9-10-11-12-13-14 mm
○ 900L 5-6-7-8-9-10-11-12-13 mm
○ 96BPC/SC9 1,5-2-2,5-3-4-5-6-8-10 mm
895/1 - 895/3 - 895/6
○ 900ME 3-4-5-6-7 mm
● 900LP 0,8x4-1x5,5-1,2x6,5-2x8 mm
● 900PH PH1-PH2-PH3-PH4
○ 900TX T10-T15-T20-T25-T27-T30-T40
900/16 □ 1/4 - ■ 3/8
900/... 50-100-150 mm
900/25 - 900BG/30 - 900/42
● 900/55
○ 910A 6-7-8-9-10-11-12-13-14-15-16-17-18-19-20-21-22 mm
910/15 □ 3/8 - ■ 1/4
910/16 □ 3/8 - ■ 1/2
910/21 125 mm
910/22 250 mm
910/25 - 910/42
● 910/55
○ 920A 8-10-11-12-13-14-15-16-17-18-19-20-21-22-23-24-26-27-28-30-32 mm
920/15 □ 1/2 - ■ 3/8
920/25
920AN 125 - 250 mm
920/42
● 920/55
○ 956E 16-17,8-20,8 mm

024500871 7,7 kg

M120

12"



- 920A 10-11-12-13-14-15-16-17-18-19-20-21-22-24-26-27-30-32 mm
- 920AN/125 125 mm
- 920AN/250 250 mm
- 920/25 - 920/42
- 920AL 10-12-13-14-15-16-17-18-19-22-24-27-30-32 mm
- 920FTX 10-12-14-16-18-20-22-24 mm
- 920/55
- 920PE 5-5L-6-6L-7-7L-8-8L-10-10L-12-12L-14-14L
- 920TX T20-T25-T27-T30-T40-T45-T50-T55-T60-T20L-T25L-T27L-T30L-T40L-T45L-T50L

024500120 6,9 kg

M128

12"

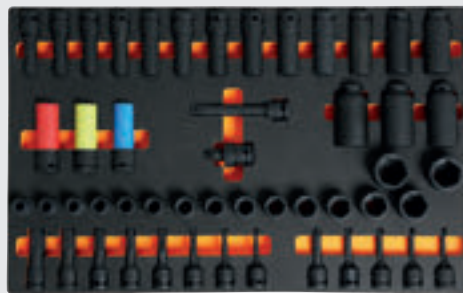

- 720 10-11-12-13-14-15-16-17-18-19-21-22-24-27-30-32 mm
- 720L 11-12-13-14-15-16-17-18-19-21-22-24-27-30-32 mm
- 720TX T30-T40-T45-T50-T55
- 720ME 5-6-8-10-12-14-17-19 mm
- 720LC 17-19-21 mm
- 720/21 125 mm
- 720/25

024500128 8,9 kg

New item

M130



- 1032 180 mm
- 1034 170 mm
- 1036 175 mm
- 1038 175 mm
- 1048 250 mm
- 1052 240 mm
- ⌘ 1082BM 160 mm
- 1098 220 mm
- 1112 250 mm
- 1128BM
- 1150BM 180 mm
- 1166BM 160 mm
- 1168BM 160 mm

024500130 3,4 kg

M195

New item

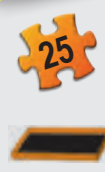
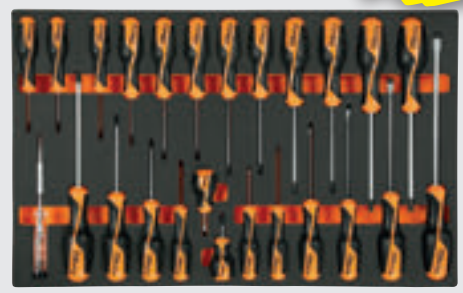

- 1260 2,5x50-3x75-4x100-5,5x125-6,5x150-8x200 mm
- 1260N 4x30 mm
- ⊕ 1262 PH0x60-PH1x80-PH2x100-PH3x150 mm
- ⊕ 1262 PH1X30 mm
- ⊕ 1267TX T6-T7-T8-T9-T10-T15-T20-T25-T27-T30-T40-T45
- 1253 3,5x100 mm

024500195 2,3 kg

M210



- 1201 2,5x50-3x75-4x100-5,5x125-6,5x150-8x200 mm
- 1201N 4x30 mm
- ⊕ 1202 PH0x60-PH1x80-PH2x100-PH3x150 mm
- ⊕ 1202N PH1X30 mm
- ⊕ 1207TX T6-T7-T8-T9-T10-T15-T20-T25-T27-T30-T40-T45
- 1253

024500210 1,8 kg

M230



- 30 Ø 2-3-4 mm
- 31 Ø 2-3-4-5-6-8 mm
- 32 Ø 4 mm
- 34 150 mm
- 35 200-250 mm
- 36 125 mm
- 1370 500 g
- 1390 Ø 35 mm
- 1692 3 m
- 1712
- 1719BMA/Q 200 mm
- ▲ 1719BMA/T 200 mm
- 1719BMA/P 200 mm
- ▶ 1719BMA/M 200 mm
- 1719BMA/R 200 mm
- 1737
- 1771 18 mm

024500230 3,2 kg



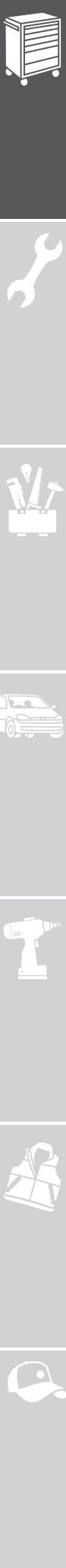

T10

42 6-7-8-10-11-12-13-14-16
17-18-19-21-22-24-27-30 mm

024240010 2,7 kg

T13 *New item*

42SLIM 8-10-11-12-13-14
15-16-17-18-19 mm

024240013 1,5 kg

T15

42 6-7-8-9-10-11-12-13-14
15-16-17-18-19-20-21 mm

024240015 1,5 kg

T16

42 22-24-27-30-32

024240016 2,1 kg

T31

31 Ø 2-3-4-5-6 mm
32 Ø 4 mm
55 6x7-8x9-10x11-12x13-14x15
16x17-18x19-20x22-21x23
24x26-27x29-30x32 mm
○ 96N/SC9 1,5÷10 mm

024240031 3 kg

T40

90 6x7-8x9-10x11-12x13
14x15-16x17-18x19 mm

024240040 810 g

T45

142 8-9-10-11-12-13-14
15-16-17-18-19 mm

024240045 1,3 kg

T50

○ 96T 2-2,5-3-3,5-4-4,5
5-6-7-8-10 mm

024240050 1,3 kg

T55

○ 97TTX T10-T15-T20 T25-
T27-T30

024240055 330 g

T63

○ 952 7-8-10-12-13-14
17-19 mm

024240063 3,8 kg

T83

○ 920A 10-11-12
13-14-15-16-17-18
19-20-21-22-23-24
26-27-30-32 mm
920/21 125 mm
920/22 255 mm
920/25
920/42 305 mm
920/55 Ⓢ 275 mm

024240083 3,6 kg

T85

● 861LP 0,5x3-0,6x4,5-0,8x5,5-1x5,5
1,2x6,5-1,2x8-1,6x8 mm
○ 861PE 2-2,5-3-4-5-6-8-10 mm
● 861PH PH0 - PH1 - PH2 - PH3
● 861PZ PZ1 - PZ2 - PZ3
○ 861TX T6-T7-T8-T9-T10-T15-T20-T25-T27-T30-T40
● 861RTX T9-T10-T15-T20-T25-T27-T30-T40
● 861TRW 1-2-3-4-5-6 mm
● 861TQS 0-1-2-3-4-5-6-8 mm
● 861SP 4-6-8-10-12 mm
851SR 230 mm
○ 900 4-4,5-5-5,5-6-7-8-9-10-11-12-13-14 mm
900/21 150 mm 900/25 41 mm
900BG/30 176 mm 900/42 115 mm
Ⓢ 900/55 125 mm 194 1/4x5/16

024240085 1 kg

T91

○ 900 4-4,5-5-5,5-6
7-8-9-10-11-12
13-14 mm
○ 900ME 2,5-3-4-5
6-8 mm
900/20 50 mm
900/21 150 mm
900/25
900BG/30 176 mm
900/42 115 mm
Ⓢ 900/55 125 mm

024240091 560 g

T92

○ 910A 6-7-8-9-10-11
12-13-14-15-16-17-18
19-20-21-22 mm
910/21 125 mm
910/22 250 mm
910/25
910/42 210 mm
Ⓢ 910/55 200 mm

024240092 1,5 kg

T103

12" 14"



- 900L 6-7-8-9-10-11-12 mm
- 920AL 13-14-16-17-18-19
21-22-24-27 mm

024240103 1,1 kg

T131



- 1084BM 160 mm
- 1150BM 180 mm
- 1166BM 160 mm

024240131 750 g

T145



- 1032 180 mm
- 1034 170 mm
- 1036 175 mm
- 1038 175 mm

024240145 640 g

T153



- 1048 250 mm
- 1052 240 mm

024240153 1,1 kg

T199



GRIP

- 1260 2,5x50 - 3x75 - 3,5x100
4x125 - 5,5x100 - 5,5x150-6,5x150 mm

024240199 490 g

T202



GRIP

- 1262 PH0x60 - PH0x100 - PH1x80
PH1x120 - PH2x100 - PH2x150 mm

024240202 490 g

T205



GRIP

- 1267TX
T6-T7-T8-T9-T10-T15-T20

024240205 460 g

T210



Beta EASY

- 1201 2,5x50-3x75-3,5x100-4x125
5,5x100-5,5x150 6,5x150 mm

024240210 490 g

T212



Beta EASY

- 1202 PH0x60-PH1x80-PH1x120
PH2x100-PH2x150-PH3x150 mm

024240212 490 g

T215



Beta EASY

- 1207TX
T6-T7-T8-T9-T10-T15-T20

024240215 410 g

T234



- 35 100-200 mm
- 1370 300 g
- 1390 ø 35 mm

024240234 1,3 kg

T236



- 1719BMA/Q 200 mm
- ▲ 1719BMA/T 200 mm
- 1719BMA/P 200 mm
- ▶ 1719BMA/M 200 mm
- 1719BMA/R 200 mm

024240236 870 g

T239



- 31BM Ø 2-3-4-5-6-8 mm
- 32 ø 4 mm

024240239 850 g





C45

COMBINATION COMPRISING:

- Fixed module with 7 drawers 566x406 mm
- Fixed service module
- Mobile roller cab with 7 drawers 532x406 mm
- Two-door tool cabinet
- 3 perforated tool panels
- 3 wall-mounted cabinets
- 3 wall brackets, wide type
- 1 wall bracket, narrow type

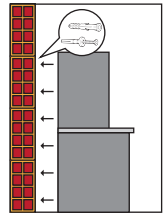

C45/X

Workshop equipment combination C45/X

- Worktop made of MDF stainless steel coated (C45PX/3-2,0MT)

045000010 294 kg



C45/W

Workshop equipment combination C45/W

- Multi-ply wood worktop (C45PW/3-2.0MT)

045000020 260 kg

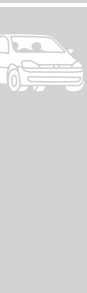
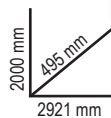

C45/B

COMBINATION COMPRISING:

- Fixed module with 5 drawers 566x406 mm
- Fixed two-door module
- Single-door tool cabinet
- 2 wall-mounted cabinets
- 2 perforated tool panels
- 2 wall brackets, wide type
- 1 wall bracket, narrow type

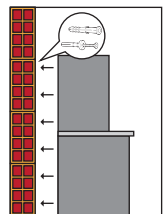

C45/BX

Workshop equipment combination C45/BX

- Worktop made of MDF stainless steel coated (C45PX/2-1.3MT)

045000043 275 kg



C45/BW

Workshop equipment combination C45/BW

- Multi-ply wood worktop (C45PW/2-1.,3MT)

045000053 260 kg

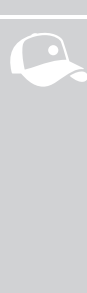
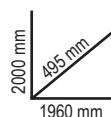

5945VUM

Assortment of 231 tools for universal use



Recommended for use in combination with mobile roller cab: C45



MM10

30



MM61

17



MM105

107



MM140

52



MM210

25

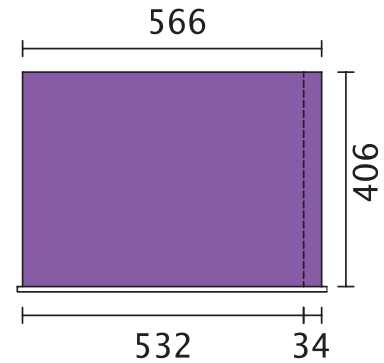

Quantity/Description

Quantity/Description	Beta N.	TR
21 combination wrenches 6-7-8-9-10-11-12-13-14-15-16-17-18-19-20-21-22-24-27-30-32 mm	42	MM10
9 offset hexagon key wrenches \odot 2-2,5-3-4-5-6-7-8 mm	96BPC/SC9	MM10
8 engineer's hammer 300 g	96T	MM61
1 soft face hammer \varnothing 35	1370	MM61
1 flat chisels, ribbed type 100-200 mm	1390	MM61
2 second cut files 200 mm	35	MM61
5 ball head offset hexagon key wrenches \odot 1,5-2-2,5-3-4-5-6-8-10 mm	1719BMA8/S5	MM61
1 socket holder \odot 1/4 - \square 1/4	895/1	MM105
1 socket holder \odot 1/4 - \square 3/8	895/3	MM105
1 socket holder \odot 5/16 - \square 1/2	895/6	MM105
13 1/4" hexagon sockets \odot 4-4,5-5-5,5-6-7-8-9-10-11-12-13-14 mm	900	MM105
9 hexagon hand sockets, long series \odot 5-6-7-8-9-10-11-12-13 mm	900L	MM105
5 1/4" socket drivers for hexagon screws \odot 3-4-5-6-7 mm	900ME	MM105
4 socket drivers for slotted head screws \bullet 0,8x4-1x5,5x1,2x6,5-1,2x8 mm	900LP	MM105
4 socket drivers for cross head Phillips® screws \oplus PH1-PH2-PH3-PH4	900PH	MM105
7 socket drivers for Torx® head screws \odot T10-T15-T20-T25-T27-T30-T40	900TX	MM105
1 adaptor, 1/4" female and 3/8" male drives \square 1/4 - \blacksquare 3/8	900/16	MM105
1 1/4" drive extension bar 50 mm	900/20	MM105
1 1/4" drive extension bar 100 mm	900/20L	MM105
1 1/4" drive extension bar 150 mm	900/21	MM105
1 1/4" drive universal joint	900/25	MM105
1 1/4" drive spinner handle 176 mm	900BG/30	MM105
1 1/4" drive swivel T-handle 115 mm	900/42	MM105
1 1/4" reversible ratchet \oplus 125 mm	900/55	MM105
17 hexagon hand sockets 3/8" \odot 6-7-8-9-10-11-12-13-14-15-16-17-18-19-20-21-22 mm	910A	MM105
1 adaptor, 3/8" female and 1/4" male drives \square 3/8 - \blacksquare 1/4	910/15	MM105
1 adaptor, 1/2" female and 3/8" male drives \square 3/8 - \blacksquare 1/2	910/16	MM105
1 extension bar - 3/8" 125 mm	910/21	MM105
1 extension bar - 3/8" 250	910/22	MM105
1 3/8" drive universal joint	910/25	MM105
1 3/8" drive sliding T - handle 210 mm	910/42	MM105
1 3/8" drive reversible ratchet \oplus 200 mm	910/55	MM105
21 1/2" square drive hexagon sockets \odot 8-10-11-12-13-14-15-16-17-18-19-20-21-22-23-24-26-27-28-30-32 mm	920A	MM105
1 adaptor, 1/2" female and 3/8" male drives \square 1/2 - \blacksquare 3/8	920/15	MM105
1 1/2" drive universal joint	920/25	MM105
1 1/2" wobble extension bar 125 mm	920AN	MM105
1 1/2" wobble extension bar 250 mm	920AN	MM105
1 1/2" drive sliding T-handle 305 mm	920/42	MM105

Quantity/Description

Quantity/Description	Beta N.	TR
1 1/2" drive reversible ratchet \oplus 275 mm	920/55	MM105
3 3/8" square drive spark plug sockets \odot 16 mm (5/8")-17,8 (11/16")-20,8 (13/16")	956E	MM105
5 drivers for Torx® head screws, with handles \odot T10-T15-T20-T25-T30	97TTX	MM140
1 heavy duty diagonal cutting nippers \llcorner 160 mm	1084BM	MM140
1 half-round needle nose pliers \equiv 180 mm	1150BM	MM140
1 extra long needle knurled nose pliers, bi-material handles \bullet 160 mm	1166BM	MM140
1 circlip pliers straight, internal \odot 19=60 mm	1032	MM140
1 circlip pliers bent, internal \odot 19=60 mm	1034	MM140
1 circlip pliers straight, external \bullet 19=60 mm	1036	MM140
1 circlip pliers bent, external \bullet 19=60 mm	1038	MM140
1 slip joint pliers boxed joints 250 mm	1048	MM140
1 self - locking pliers 240 mm	1052	MM140
38 microscrewdriver with 36 interchangeable 4-mm bits and magnetic extension	1256/C36-2	MM140
6 screwdrivers for cross head Phillips® screws \bullet 04x2,5x50-0,5x3x75-0,8x4x100-1,0x5,5x125-1,2x6,5x150-1,2x8x200 mm	1201	MM210
1 screwdrivers for slotted head screws, extra-short series \bullet 0,8x4x30 mm	1201N	MM210
4 screwdrivers for cross head Phillips® screws \oplus PH0x60-PH1x80PH2x100PH3x150 mm	1202	MM210
1 screwdrivers for cross head Phillips® screws, extra-short series \oplus PH1x30 mm	1202N	MM210
12 drivers for Torx® head screws, with handles \odot T06-T07-T08-T09-T10-T15-T20-T25-T27-T30-T40-T45	1207TX	MM210
1 mains testing screwdriver \bullet 0,5x3,5x100 mm	1253	MM210

059450001 19,6 kg





C56B

Workbench with wood top

Main features:

- Multi-ply wood worktop with holes for a vice (1599F/125, to be ordered separately)
- Steel frame with 4 supporting legs
- Lower object shelf
- Can be fixed to floor



930 mm

62 kg



C56B

056000401

056000402

056000403

C56

Workbench

- Worktop made of painted sheet metal with external edge
- Steel frame with 6 supporting legs
- Two drawers with lock
- Can be fixed to floor

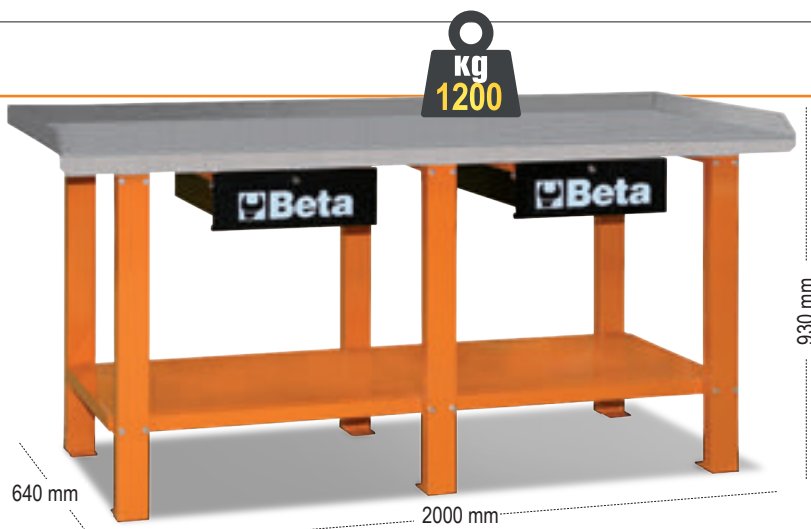

930 mm

82 kg



C56

056000201

056000202

056000203

C59A

Workbench with 1 cab with six drawers

Main features:

- Worktop made from multi-ply wood with holes for vice item 1599F/125 (to be ordered separately)
- 6 drawers (588x367 mm) with ball bearing slides
- Drawers protected by foamed rubber mats
- Hard-wearing nylon drawer front
- Roller cabs can accommodate thermoformed trays
- Front centralized safety lock
- Lower object shelf
- Can be fitted with paper roll holder (2400S-R/PC) and bottle holder (2400S/PF), to be ordered separately



900 mm

n°	h	max
4	70 mm	25 kg
1	140 mm	30 kg
1	280 mm	35 kg

115 kg



C59A

059000001

059000021

059000041



C58B

Workbench with wood top

Main features:

- Multi-ply wood worktop with holes for a vice (1599F/125, to be ordered separately)
- Steel frame with 4 supporting legs
- Lower object shelf
- Can be fixed to floor

59 kg



C58B

058000401

058000402

058000403



C56P0

Folding workbench

- 30-mm-thick worktop made of MDF and galvanized sheet iron; can be used on both sides
- Handle with rubber protection for easy transport
- Feet with anti-slip coating

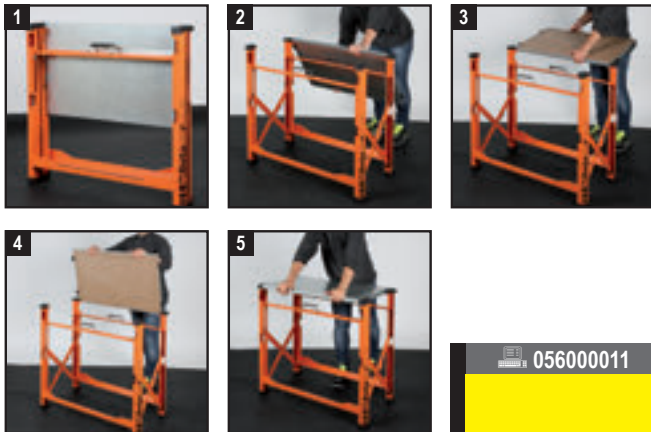

056000011

25 kg



C51

Trolley

- 3 tops covered in antislip ribbed rubber
- Two fixing options for central worktop
- Four castors Ø 100 mm: 2 fixed and 2 steering (1 with brake)

21 kg



C51

051000001

051000002

051000003





C27S

Folding tool trolley for outdoor jobs, empty

- Folding tool trolley. Its unique patented design guarantees an effortless transport
- 2 drawers, 588x277 mm, with ball bearing slides, for two-way opening
- Large lower object compartment, 588x277x220 mm
- Sheet metal frame
- 2 fixed castors, Ø 160 mm, and 2 steering castors with brake, Ø 100 mm
- Thermoplastic worktop with 6 built-in tool trays
- Centralized lock
- Can accommodate drawer partitions and MC foam tool trays



n°	h	↓ max
2	70 mm	20 kg



20 kg

C27S	027000201	027000202	027000203	
------	-----------	-----------	-----------	--

5927VU/M



Assortment of 108 tools in soft foam tray for C27S trolley

for drawer: 588x277 mm



MC10



MC20

059270021 8,3 kg

C41H

Two-module tool trolley

Main features:

- Sheet metal frame and plastic tops, synonymous with remarkable sturdiness and reduced weight
- 2 detachable modules:
 - 1 upper tool box,
 - 1 module with 2 drawers 95 mm in height,
 - 1 pull-out case made of plastic, 66 mm high, and 1 drawer 295 mm in height
- Oversized castors (160 mm), built into frame for easy transport - for example, on steps
- Side centralized lock for closing drawers of lower module
- Drawers with ball bearing slides and double closing hook
- Telescopic aluminium handle
- Small tool holder built into upper tool box
- Lower drawer with double ballbearing slide



C41H W
RAL 9016

C41H Y
RAL 1023

C41H R
RAL 3000

C41H V
RAL 6016

C41H B
RAL 5002

C41H G
RAL 7016

C41H N
RAL 9005

21 kg

C41H	041000002	041000021	041000012	041000008	
	041000024	041000006	041000010	041000005	



Tool box, made from plastic, removable tote-tray and tool trays, empty

- 2 removable tool trays built into cover with adjustable partitions
- 1 interior tote-tray with adjustable partitions
- Carrying capacity: 30 kg

CP15L



558x277x270 mm



021150202 2,5 kg

CP15



445x240x250 mm

021150201 2 kg

C14

Tool trolley, made of polypropylene, with 4 drawers, empty

- Injection polypropylene frame for increased shock resistance
- 4 sturdy rear castors
- 3 tote-trays included
- Nameplate
- Can be closed with TSA lock

Removable top tray



580x380x455 mm

- Lid-protected front accommodates 4 pull-out drawers (470x255):
 - 1 drawer 30 mm high
 - 2 drawers 60 mm high
 - 1 drawer 90 mm high



Front centralised lock allows top and front lids to be closed simultaneously



Two side handles

021140000 10 kg

5914VU/M



Assortment of 109 tools for trolley C14, in soft foam tray



MC T1



MC T2

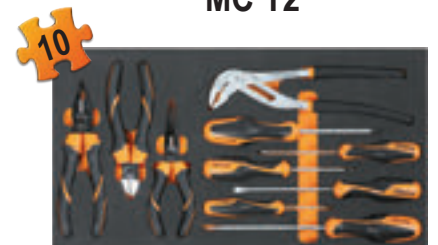

MC T3

* When used in combination with tool trolley C14, remove upper tool panel.

• assortment only

059140111 8,5 kg





C20L

Five-section cantilever tool box, made from sheet metal, empty



550x200x210 mm

021200002 5,4 kg

C16

Tool box, made of plastic, with interior object compartment, empty



500x260x260 mm

021160000 2,5 kg

C20TSS

Five-section cantilever tool box, made of AISI 304 stainless steel can be used in critical environments - that is, in areas where the minimum contamination level is not permitted -, is resistant to rust and the main acids, and can be autoclave sterilized at 121 °C.



450x200x210 mm

021203001 4 kg

2080/V6

Organizer tool case with 6 removable tote-trays and adjustable partitions

Removable, folding clear tote-trays, for immediate recognition of contents



4385x320x60 mm

020800060 1,2 kg

CP17

Tool box, made of stainless steel and plastic, removable tote-tray, empty



500x200x220 mm

021170500 2,5 kg



2080/V12

Organizer tool case with 12 removable tote-trays

Removable, folding clear tote-trays, for immediate recognition of contents



300x330x145 mm

020800000 1,8 kg

Technical fabric tool bags

Lightweight and sturdy, for absolutely safe transportation of your tools



C5

- Rucksack, empty**
- Removable interior tool panel
 - Six exterior pockets and two interior pockets
 - Waterproof plastic base
 - Double safety lace for fixing rucksack to shoulders
 - Ergonomic padded back



021050000 2,5 kg

500x400x180 mm

C6T

- Rucksack with castors, empty**
- Telescopic handle for easy transport
 - Built-in castors with practical dustproof cover for use as a rucksack
 - Two removable tool panels
 - Interior PC pocket and five exterior pockets
 - Waterproof plastic base



021060010 4,5 kg

480x370x220 mm

C7

- Bag, empty**
- 2 removable interior tool panels
 - 2 exterior front pockets
 - Interior bottom made of plastic, with removable partitions



021070000 3,5 kg

440x370x170 mm

C11

- Box, empty**
- Hard water resistant plastic base
 - Elastic tool bands and interior and exterior tool pockets
 - Document holders built into double bottom of cover



021110000 2 kg

400x240x220 mm

C8

- Trolley, empty**
- Telescopic carrying handle
 - 2 removable interior tool panels
 - Interior PC pocket and 2 exterior front pockets
 - Can accommodate tool box item C10S



021080000 4 kg

470x370x280 mm

Box, empty

- Hard frame
- Double bottom.
- Tilting handle for easier access to tools
- Elastic tool bands and interior and exterior pockets
- Cover
- Tool tray included in double bottom
- Can be used with trolley C8



C10S

420x220x250 mm

021100001 2,3 kg

C10

520x220x250 mm

021100000 3,3 kg



2029/VV

Tool case, made of thick polypropylene, aluminium edged, empty
 • 2 interior tool panels

≡ 490x380x230 mm

020290000 6,1 kg



2038/TV

Tool trolley, made of thick polypropylene, empty

- Highly shock resistant
- Aluminium sealing profile
- Telescopic handle and big ball bearing castors
- Capacious bottom
- Document pocket
- 3 tote drawers

≡ 430x500x340 mm

2 removable tool panels

020380000 9 kg



2 ergonomic rubber-coated handles (including 1 side handle)



2 TSA approved locks with keys



2028/VV

Tool trolley, made of thick polypropylene, empty

- 2 tool panels
- Interior bottom with removable partitions
- Double combination lock



020280010 4,5 kg

≡ 470x185x410 mm



42/SP15

New item

Set of 15 combination wrenches with holder



NEW DESIGN



6-7-8-9-10-11-12-13
14-15-16-17-19-22-24 mm

000421078 2,1 kg

42/SC9I

Set of 9 combination wrenches

- compact, practical, easy-to-carry support
- quickly identified wrench size
- wrench safely locked in support

NEW DESIGN



8-10-11-12-13-14-15-17-19 mm



000421087 890 g

New item

42INOX/SC9

Set of 9 combination wrenches made of stainless steel with compact support

8-10-11-12-13-14-15-17-19 mm



000420387 812 g



NEW DESIGN

Our epoch-making wrench 42 has a new shape. A stylish, slim shape enhanced by a slender profile, lighter to the touch, head thickness having been reduced to a minimum, to allow you to gain proper access to all spaces. The **strength, resilience and rapidity** of use of the Beta wrench reach even higher values, to provide users with the best possible tool. The **manufacturing process** is carried out in our factories in Sovico and Sulmona, on the basis of state-of-the-art automation technology and the best trained workers.

Rapid

A 15 degree angle compared to the axis, to reduce the take-up angle

Resilient

Remarkable strength: in case of improper use, the wrench buckles, without breaking suddenly and dangerously

Homogeneous

Pressing is based on a round-section semi-finished product which results in homogeneously distributed fibres, thereby preventing dangerous internal stress formation

Accessible

Reduced thickness for improved accessibility

Protected

Nickel-chrome plating provides lasting resistance to external agents and meets the stringent requirements of adhesion tests under ISO 2819

Powerful

Torque values more than doubled compared to the requirements to be satisfied under ISO 1711

Optimized

The wrench, which is longer than most competitors', allows high torques to be obtained through reduced effort

Ergonomic

The offset ring has a 15 degree angle to protect the hand. The shape is obtained from a die; it is not bent later.



MADE IN ITALY



141/B9 *New item*

Set of 9 ratcheting combination wrenches, straight series, in cloth wallet

8-10-11-12-13-14-15-17-19 mm

001410069 900 g

42SLIM/B81 *New item*

Set of combination wrenches with thin open ends, in wallet
Thinner head

10-11-12-13
14-15-17-19 mm

000420468 700 g

42SLIM 42

142/SC9I

Set of 9 reversible ratcheting combination wrenches, with compact support

8-10-11-12-13-14-15-17-19 mm

001420087 1,2 kg

142SN/SC9

Set of 9 swivel end ratcheting combination wrenches with compact support

8-10-11-12-13-14-15-17-19 mm

001420259 1,3 kg

192/S2

Set of 2 reversible ratcheting offset bi-hex ring wrenches

8 sizes in 2 wrenches

13 mm 10 mm
12 mm 8 mm
19 mm 17 mm
18 mm 16 mm

001920070 500 g

55/SP7

Set of 7 double open end wrenches with holder

6x7-8x9-10x11-12x13
14x15-16x17-18x19 mm

000550167 920 g

111

Adjustable wrenches with scales, chrome-plated

- Movable jaw opening with right-hand rotation of pin
- Head angled at 22.5 degrees, with mm and inch scale



	L mm	A max	g		
111/100	100	15 mm	60	001110010	
111/150	150	24 mm	165	001110015	
111/200	200	28 mm	325	001110020	
111/250	250	34 mm	505	001110025	
111/300	300	35 mm	790	001110030	
111/450	450	54 mm	2043	001110045	
111/600	600	62 mm	3300	001110060	

mm/inch readout

90/S7

Set of 7 double ended deep offset ring wrenches

- 6x7-8x9-10x11-12x13-14x15-16x17-18x19 mm



000900163 800 g

96T/S5P

Set of 5 offset hexagon key wrenches with handles

- 2,5-3-4-5-6 mm



000960946 300 g

97TTX/S6

Set of 6 ball head offset key wrenches for Torx® head screws with handles

- T10-T15-T20-T25-T30-T40



000970791 400 g

951/S6

Set of 6 T-handle wrenches with three hexagon male ends

- 2,5-3-4-5-6-8 mm



009510687 600 g

952/D7

Set of 7 T-handle wrenches with swivelling hexagon sockets

- 7-8-10-12-13-14-17 mm

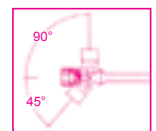

009520079 2,5 kg



96/SC9

Set of 9 offset hexagon key wrenches



Ø mm	L mm
1,5	42
2	48
2,5	59
3	62
4	70
5	81
6	92
8	102
10	116

000960374 300 g

97BTXL/SC8

Set of 8 ball head offset key wrenches, long model, for Torx® head screws



Ø mm	L mm
T9	83
T10	89
T15	103
T20	114
T25	130
T27	145
T30	166
T40	183

000970364 240 g

96BP-CL/SC9

Set of 9 ball head offset hexagon key wrenches, coloured

Extra long version +30%

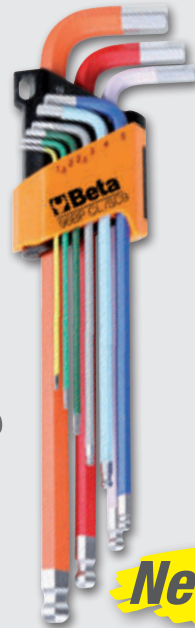

Ø mm	L mm
1,5	91
2	100
2,5	113
3	130
4	142
5	163
6	185
8	205
10	231

New item

000961619 440 g

97BTX/SC8

Set of 8 ball head offset key wrenches, for Torx® head screws



Ø mm	L mm
T9	65
T10	74
T15	84
T20	96
T25	98
T27	109
T30	123
T40	136

000970164 170 g

96BPC/SC9

Set of 9 ball head offset hexagon key wrenches



Ø mm	L mm
1,5	79
2	85
2,5	89
3	100
4	110
5	129
6	152
8	173
10	194

000960354 400 g

96LBP/SC9

Set of 9 ball head offset hexagon key wrenches

Extra long version +30%



Ø mm	L mm
1,5	91
2	100
2,5	113
3	130
4	142
5	163
6	185
8	205
10	231

000961354 500 g

1297TX/LS5 *New item*

Set of 5 Beta Max screwdrivers for Torx® head screws
 ☉ T15-T20-T25-T30-T45

Long version

012970325 620 g

☉	L (mm)	L1 (mm)
T15	210	319
T20	210	319
T25	210	319
T30	210	330
T45	210	342

Beta max
MAXIMUM PERFORMANCE

944BX/D6

Set of 6 deep, hi-torque hexagon nut spinners long series

009440056 1 kg

☉ 5-6-7-8-10-13 mm

Beta max
MAXIMUM PERFORMANCE

1293/D8

Set of 8 screwdrivers

012930403 730 g

1290 ● 3x75-4x100-5,5x150-6,5x150 mm
 1292 ☉ PH0x60-PH1x80- PH2x100 mm

Beta max
MAXIMUM PERFORMANCE

1203/D8P

Set of 8 screwdrivers

1201 ● 2,5x50-3x75-4x100-5,5x100-6,5x150 mm
 1202 ☉ PH0x60-PH1x80- PH2x100 mm

012030018 640 g

1203/D10N

Set of 10 screwdrivers

1201 ● 2,5x50-3x75-4x100-5,5x150-6,5x150 mm
 1202 ☉ PH0x60-PH1x80- PH2x100 mm
 1201N ● 4x30 mm
 1202N ☉ PH1x30 mm

012030019 740 g

1207TX/D7

Set of 7 screwdrivers

1207TX ☉ T6-T8-T10-T15-T20-T25-T30

012070207 560 g

Beta
EASY

1263/D8

Set of 8 screwdrivers

1260 ● 2,5x50-3x75-4x100-5,5x125-6,5x150 mm
 1262 ☉ PH0x60-PH1x80- PH2x100 mm

012630008 600 g

1263/D10

Set of 10 screwdrivers

1260 ● 3x75-3,5x100-4x125-5,5x150-6,5x150 mm
 1262 ☉ PH0x60- PH1x8- PH2x100 mm
 1260N ● 4x30 mm
 1262N ☉ PH1x30 mm

012630010 690 g

1267TX/D7

Set of 7 screwdrivers

1267TX ☉ T6-T8-T10-T15-T20-T25-T30

012670307 500 g

Beta
GRIP

1293INOX/D8

Set of 8 stainless steel screwdrivers

012930408 551 g

1290INOX ● 2,5x50-3x75-4x100-5,5x125-6,5x150 mm
 1292INOX ☉ PH0x60-PH1x80- PH2x100 mm

Beta
INOX
STAINLESS STEEL

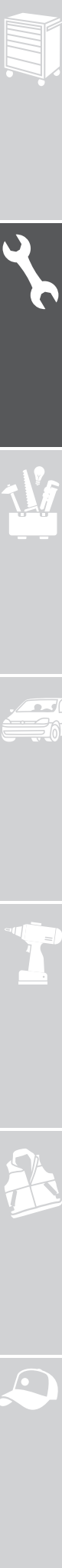

12" 14" 38"

Reversible ratchet

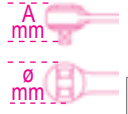

	L mm	Ø mm	A mm	■	g	
900/55	125	25	18	1/4"	90	009000870
910/55	200	30	33	3/8"	239	009100882
920/55	275	40	43	1/2"	475	009200882

12" 14" 38"

Reversible ratchet with rotating handle

- Ring nut reversal system on ratchet head
- Bi-material handle

Rotating the handle clockwise and anticlockwise will make the bit turn quickly

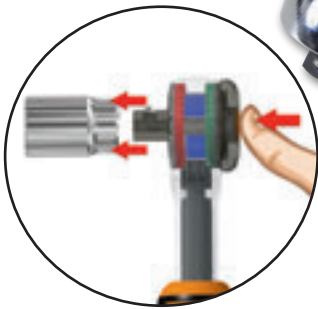

Socket release button

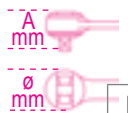

	L mm	Ø mm	A mm	■	g	
900/58	126	28	28,5	1/4"	155	009000884
910/58	222	37	38,5	3/8"	417	009100884
920/58	281	42,5	45	1/2"	705	009200926

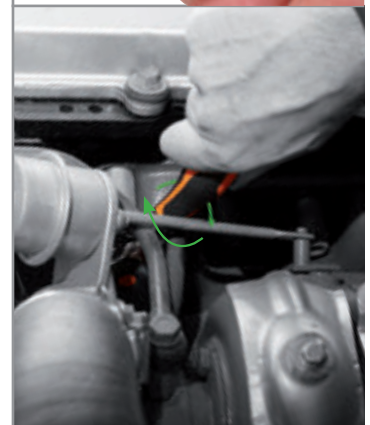

920INOX/C16

12"

Set of 15 sockets and 1 ratchet, made of stainless steel, in plastic case



	920INOX-A	10-12-13-14-15 16-17-18-19-21 22-24-27-30-32 mm
	920/55INOX	



STAINLESS STEEL + NO STAINLESS STEEL = RUST



STAINLESS STEEL + STAINLESS STEEL = NO RUST

BETA INOX TOOLS CAN BE AUTOCLAVE STERILIZED AT 121°C

009203916	3,1 kg
-----------	--------

387x174x65 mm

1 1/4" 1/4"

Assortment of 11 hexagon sockets, 21 bits and 7 accessories in plastic case



	861LP	●	0,6x4,5-1,2x6,5-1,2x8 mm
	861PE	○	2,5-3-4-5-6 mm
	861PH	⊕	PH1-PH2-PH3
	861PZ	⊕	PZ1-PZ2-PZ3
	861RTX	⊕	T10-T15-T20-T25-T27-T30-T40 mm
	892/0	●	1/4" - 1/4"
	895/1	○	1/4" - 1/4"
	900	○	5-5,5-6-7-8-9-10-11-12-13-14 mm
	900/20		50 mm
	900/20L		100 mm
	900/25		
	900BG/30C		128 mm

900/C39

reversible ratchet (900/55)

009000937 785 g



900/C39-R

reversible ratchet with rotating handle (900/58)

009000938 840 g



1 1/4" 1/4"

Assortment of 12 hexagon sockets, 20 bits and 7 accessories, in metal case

350x150x50 mm



	861LP	●	0,5x3-0,8x5,5-1x5,5-1,2x6,5 mm
	861PE	○	3-4-5-6-8 mm
	861PH	⊕	PH0-PH1-PH2-PH3
	861TX	⊕	T8-T10-T15-T20-T25-T30-T40
	895/1	○	1/4" - 1/4"
	900	○	4-5-5,5-6-7-8-9-10-11-12-13-14 mm
	900/20		50 mm
	900/21		150 mm
	900/25		
	900/42		115 mm
	900BG/30		128 mm

900/C12M

reversible ratchet (900/55)

009000963 1,2 kg



900/C12MR

reversible ratchet with rotating handle (900/58)

009000962 1,3 kg



1 1/2" 1 1/4"

902A/C22

Assortment of 22 hexagon sockets and 6 accessories, in metal case

1 1/4"		900	○	5-5,5-6-7-8-9-10-11-12-13 mm
		900/20		50 mm
		900/25		
1 1/2"		900/55	⊕	
		920A	○	10-13-14-15-17-18-19-22-24-27-30-32 mm
		920/21		125 mm
		920/25		
		920/55	⊕	

009020807 3,5 kg



420x185x60 mm





30"

Assortment of 16 hexagon sockets and 5 accessories in foam tray, in metal case



335x145x60 mm

	910A	6-7-8-9-10-11 12-13-14-15-16 17-18-19-21-22 mm
	910/21	125 mm
	910/22	250 mm
	910/25	
	910/42	210 mm

910A/C16

reversible ratchet (910/55)

009100936 2,3 kg



910A/C16HR

reversible ratchet with rotating handle (910/58)

009100935 2,4 kg



30"

Assortment of 17 hexagon sockets and 5 accessories in foam tray, in metal case



420x185x60 mm

	920A	10-11-12-13-14-15-16-17-18-19 20-21-22-24-27-30-32 mm
	920/21	125 mm
	920/22	255 mm
	920/25	
	920/42	305 mm

920A/C17M

reversible ratchet (920/55)

009200924 5 kg



920A/C17MR

reversible ratchet with rotating handle (920/58)

009200937 5,1 kg



928A/C12

Assortment of 12 hexagon hand sockets and 5 accessories, in metal case



530x220x80 mm

	928A	22-24-27-30-32-34-36-38-41 46-50-55 mm
	928/21	200 mm
	928/22	380 mm
	928/25	
	928/42	450 mm
	928/55	⊗

009280955 13,5 kg



34"

861PB

New item 

Set of 6 bits in fabric bracelet with magnetic clasp

Magnetic bit holder



Allows bit to be changed with one hand

MIX1

- ⊕ 861PH PH1 - PH2
- ⊕ 861PZ PZ1 - PZ2
- 861PE 4 - 5 mm

008610956 61 g



MIX2

- ⊕ 861PH PH2
- ⊕ 861PZ PZ2
- 861TX TX20 - TX25
TX30 - TX40

008610966 61 g



860MIX/A10



Set of 10 bits with magnetic bit holder, in plastic case

- ⊕ 860LP 0,5x3-1,0x5,5-1,2x6,5 mm
- ⊕ 860PH PH1-PH2 (x2)-PH3
- ⊕ 860PZ PZ1-PZ2-PZ3
- 882M1 ○ 1/4" - ● 1/4"



008600900 130 g



860/C27



Set of 25 bits, 1 connector and 1 reversible ratchet in plastic case



- ⊕ 860LP 0,5x3-1,0x5,5-1,2x6,5 mm
- 860PE 2-2,5-3-4-5-6-mm
- ⊕ 860PH PH1-PH2(x2)-PH3
- ⊕ 860TX T6-T8-T10-T15-T20-T25-T30-T40
- ⊕ 860PZ PZ1 - PZ2(2x) - PZ3
- 860/55 100 mm
- 892/0



008600880 320 g

860MIX/A31



Set of 30 bits with magnetic bit holder in plastic case

- ⊕ 860LP 0,5x3 - 0,6x4,5 - 0,8x5,5
1,0x5,5 - 1,2x6,5 mm
- 860PE 2-2,5-3-4-5-6-8-10 mm
- ⊕ 860PH PH0 - PH1 - PH2 - PH3 - PH4
- ⊕ 860RTX T9-T10-T15-T20-T25-T27-T30-T40
- ⊕ 860PZ PZ1 - PZ2 - PZ3 - PZ4
- 882MSR/50 ○ 1/4 ● 1/4

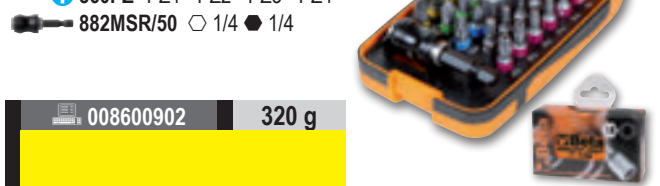

008600902 320 g

860TX/A10



Set of 10 bits with magnetic bit holder, in plastic case

- 860TX T7-T8-T9-T10-T15-T20
T25-T27-T30-T40
- 882M1 ○ 1/4 ● 1/4

008600970 130 g



862F/A7



Set of 7 magnetic bits, hexagon sockets, in plastic case

- 862F ○ 5,5-6-7-8-10-12-13 mm

008620950 350 g



605E

14"

Click-type torque wrenches with reversible ratchets for right-hand and left-hand tightening torque accuracy: ± 6%



UNI EN 26789 ISO 6789

	Nm	kgfm	lbf.in	■	L (mm)	g	
605E/5	1÷5	0,1÷0,5	10÷45	1/4"	190	180	006050105
605E/10	2÷10	0,2÷1,0	18÷90	1/4"	190	180	006050110

666N

14" 38" 12"

Click-type torque wrenches with reversible ratchets. For right-hand tightening torque accuracy: ± 3%



UNI EN 26789 ISO 6789

	Nm	kgfm	lbf.ft	■	L (mm)	g	
666N/2	5÷25	0,5÷2,5	4÷18	1/4"	220	300	006660002
666N/2X	5÷25	0,5÷2,5	4÷18	3/8"	220	300	006660003
666N/5	10÷50	1÷5	7÷37	3/8"	325	660	006660005
666N/10	20÷100	2÷10	15÷75	3/8"	367	730	006660010
666N/10X	20÷100	2÷10	15÷75	1/2"	367	800	006660011
666N/20	40÷200	4÷20	30÷150	1/2"	465	1010	006660020
666N/30	60÷300	6÷30	50÷220	1/2"	581	1380	006660030



677/C

34"

Break-back torque wrenches with push-through ratchets, for right-hand and left-hand tightening, torque accuracy: ±4%, in case



677/C100

UNI EN 26789 ISO 6789

	Nm	kgfm	lbf.ft	■	L (mm)	g	
677/C50	100÷500	10÷50	70÷350	3/4"	915	5,2	006770606
677/C70	150÷700	15÷70	100÷500	3/4"	1140	6,2	006770611
677/C100	300÷1000	30÷100	200÷750	3/4"	1470	7,5	006770615

682

Electronic digital torque meter with transducer Dynatester 682 to be used either clockwise or anticlockwise Remarkable reading accuracy

Supplied with serial output RS 232 for printers

682/60

10

682/400

22



	Nm	kg	
682/60	1.2÷60	5,9	006820006
682/400	8÷400	6,1	006820040

TECHNICAL FEATURES
 Reading accuracy ± 1% of the read value
 Available measuring units
 Nm-dNm-cNm-Lbf.ft-Lbf.in-Ozf.in-Kgf.m-Kgf.cm-gf.cm
 Supply range 90 to 264 V AC at 50/60 Hz
 Dimensions 235x185x185 mm
 Tolerance test according to norm ISO 6789
 Acceptability range for each torque wrench tested
 Display: menu available in 11 languages
 Provided with all certificates required
 Calibration certificate with UKAS traceability

665

3/8" 12"

Mechanical torque wrench with digital setting and reversible ratchet, for right-hand tightening, torque accuracy $\pm 3\%$

- Auto power off after 30" when torque is set under minimum torque threshold
- Display will remain on with set torque value
- Torque setting to decimal digit
- Power supply: 1 battery 3V (included)

MADE IN ITALY

665/SW

Digital torque calibration device

Device allows calibration of wrenches item 665 with help of torque meters 680 and 682, without having to dismantle wrench. Fitted with a micro USB port, for firmware updates.



006650100 40 g

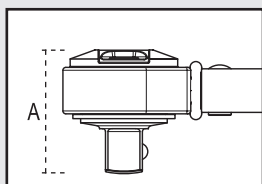
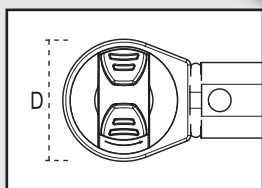

Quick, accurate digital torque adjustment

UNI EN 26789 ISO 6789

	Nm	■	D (mm)	A (mm)	L (mm)	g	🖨️	
665/6	10÷60	3/8	30	33	335	655	006650006	
665/10	20÷100	3/8	30	33	375	725	006650010	
665/10X	20÷100	1/2	30	37	375	725	006650011	
665/20	40÷200	1/2	40	43	470	995	006650020	
665/30	60÷330	1/2	40	43	590	1260	006650030	



560/...

Torque multiplier for right-hand and left-hand tightening, in plastic case, ratio 3.8:1

- multiplies tightening and untightening force
- only for use with torque wrenches
- maximum input torque: 395 Nm

New item



560/C3

1500 Nm Max

005600030 4 kg

560/C3PLUS

2700 Nm Max

005600038 7,5 kg



1169/D4

Set of 1 combination pliers,
1 long needle nose pliers,
1 cutting nippers and 1 slip joint pliers
with boxed joints

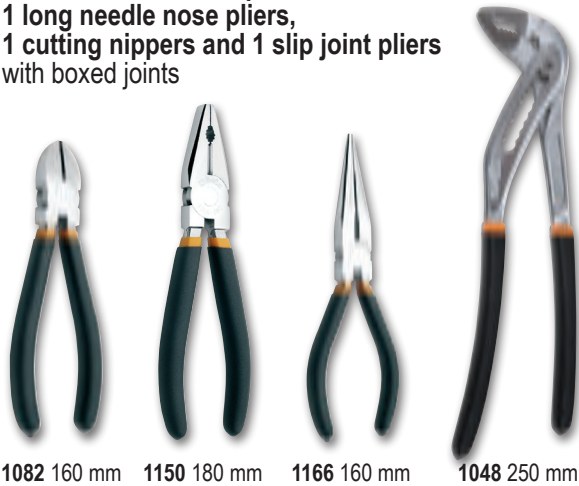

1082 160 mm 1150 180 mm 1166 160 mm 1048 250 mm

011690004 1,1 kg



1169BM/D3

Set of 1 combination pliers, 1 long needle nose
pliers and 1 diagonal cutting nippers



1082BM 160 mm

1150BM 180 mm

1166BM 160 mm

011690123 700 g

1052

Adjustable self-locking pliers,
concave jaws

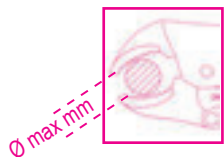

	L mm	ø Max mm	g	
1052/140	140	22	175	010520014
1052/190	190	36	360	010520019
1052/240	240	42	590	010520024

1057A

Automatic self-locking pliers
with adjustable force

010570124 620 g



1031/S4

Set of 4 circlip pliers

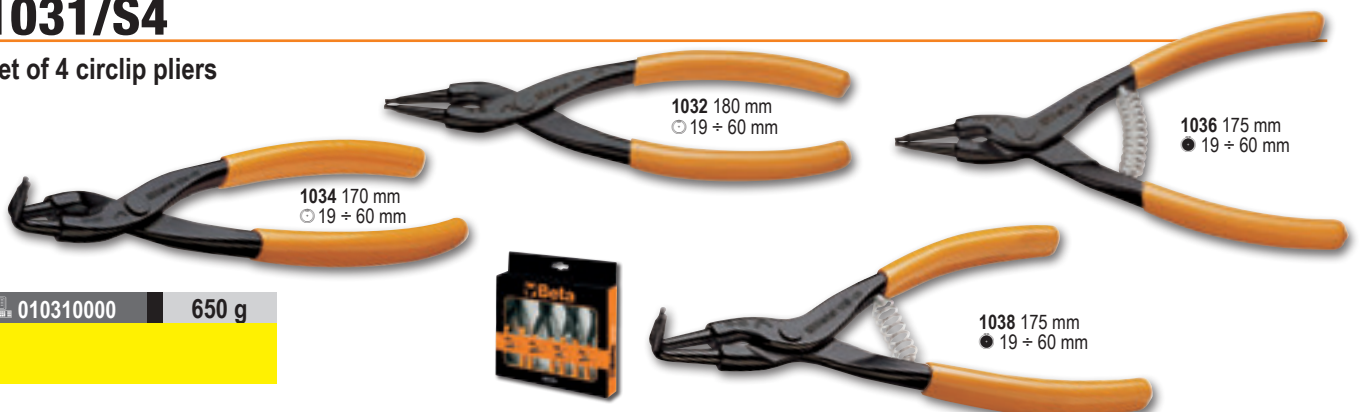

1034 170 mm
⊙ 19 ÷ 60 mm

1032 180 mm
⊙ 19 ÷ 60 mm

1036 175 mm
● 19 ÷ 60 mm

1038 175 mm
● 19 ÷ 60 mm

010310000 650 g



1150INOX

Heavy-duty combination pliers, made of stainless steel

- Decentralized pin
- Open joint

180 mm

Beta
INOX
STAINLESS STEEL



New item

MADE IN ITALY

011500518

227 g

1150HPC

New item

Heavy duty combination pliers with integrated cutting edges and decentralized pin
Matt chrome-plated finish,
bi-material handles, open joint

Patent pending

Hardness of M2 steel cutting edges = **65HRC**

Shearing stress - static test = **-73%**

Average life of cutting edges (test ISO 5744) **+127%**

180 mm

Matt chrome-plated finish

- *Absolutely groundbreaking*
- *remarkable cutting capacity*

Cutting edge hardness: 65HRC

MADE IN ITALY

011500618

290 g

1047/240

Slip joint pliers, push button alignment

- Quick, accurate adjustment by pressing push button
- No accidental misadjustment
- Heat-treated jaws

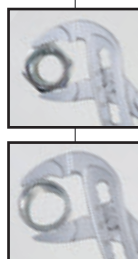

L 240 mm ø Max 36 mm Max 32 mm

010470240

340 g

1048

Slip joint pliers, boxed joints

- Slip joint pliers, boxed joints



9-positions model

L 250 mm ø Max 50 mm Max 48 mm

010480015

370 g

1009L/DP-S2

Set of 2 extra-long, knurled double swivel nose pliers

- Suitable for jobs in hard-to-access areas



45°

1009L/DP

L 340 mm

1009L/D

010090060

920 g



412M/SP19

New item

Set of 19 twist drills with cylindrical shanks, HSS, AISI M2, entirely ground finishing

- Self-centring
- High performance and cutting accuracy
- For drilling alloy steel, cast iron and metal in general

Ø 1÷10 x 0,5 mm

R ≤ 850 N/mm²
HV ≈ 820
DIN 338

004120469 590 g



415CO/SP19A

Set of 19 twist drills with cylindrical shanks, HSS-CO 5%

- For drilling holes into STAINLESS steel, alloy steel, cast iron, mild steel, light alloys

Ø 1÷10 x 0,5 mm

R ≤ 1400 N/mm²
HV ≈ 850-920
DIN 338

115x170x40 mm

004150440 590 g



412/SP25P

New item

Twist drills with cylindrical shanks, short series, HSS, entirely ground glossy finishing

Ø 1÷13 x 0,5 mm

R ≤ 700 N/mm²
HV ≈ 750-820
DIN 338

004120415 1,1 kg



426HS/SP10

Set of 10 rotary cutters made of HSS, 6-mm tang

- 5 coarse cutters: for light alloys, copper, brass and bronze
- 5 second-cut cutters: for steel and cast iron

New item

004260210 400 g



446/C110

Assortment of 105 chrome-steel taps and dies, metric thread, and 5 accessories for car repair jobs in wooden case



500x337x60 mm

004460060 8 kg

435/0 444/1 436/1
435/3 444/2

430 M mm	433 M mm	440/440A M mm	441/441A M mm
2x0,4	6x0,75 - 7x0,75	2x0,4	6x0,75 - 7x0,75
3x0,5	8x0,75 - 8x1	3x0,5	8x0,75 - 8x1
4x0,7	9x0,75 - 9x1	4x0,7	9x0,75 - 9x1
5x0,8	10x0,75 - 10x1	5x0,8	10x0,75 - 10x1
6x1	10x1,25 - 11x0,75	6x1	10x1,25 - 11x0,75
7x1	11x1 - 11x1,25	7x1	11x1 - 11x1,25
8x1,25	12x0,75 - 12x1	8x1,25	12x0,75 - 12x1
9x1,25	12x1,25 - 12x1,5	9x1,25	12x1,25 - 12x1,5
10x1,5	14x1 - 14x1,25	10x1,5	14x1 - 14x1,25
11x1,5	14x1,5 - 16x1	11x1,5	14x1,5 - 16x1
12x1,75	16x1,5 - 18x1,5	12x1,75	16x1,5 - 18x1,5
14x2		14x2	
16x2		16x2	

425/SP3

Set of 3 stepped drills HSS

Ø 4÷30 mm

004250030 450 g



31BM/D6

Set of 6 pin punches with handles

Ø 2-3-4-5-6-8 mm



000310420

805 g

32AU

Automatic centre punches



L 150 mm

000320160

135 g

1370

Mechanic's hammers wooden shaft



	g	g		
1370/300	300	439	013700053	
1370/500	500	669	013700055	
1370/800	800	949	013700058	
1370/1000	1000	1180	013700060	
1370/1500	1500	1722	013700065	
1370/2000	2000	2181	013700070	

1370T

Mechanic's hammers fibre shaft



	g	g		
1370T/300	300	452	013700630	
1370T/500	500	663	013700650	
1370T/800	800	1017	013700680	
1370T/1000	1000	1279	013700700	
1370T/1500	1500	1740	013700750	

1390

Soft face hammers, wooden shafts



	Ø mm	g		
1390/22	22	134	013900022	
1390/28	28	230	013900028	
1390/35	35	365	013900035	
1390/45	45	698	013900045	
1390/60	60	1462	013900060	



334

Pipe cutter for copper and light alloy pipes

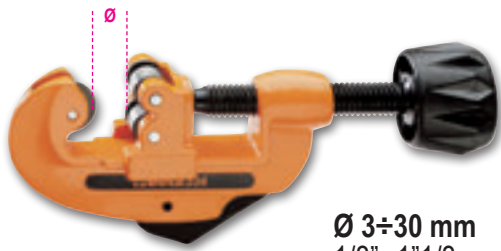

003340001 292 g

342

Ratchet-type shears for plastic pipes



003420030 500 g

Ø 0÷42 mm
1 1/8"

363

Heavy duty pipe wrenches made from light alloy



	L (m)	Ø (")	Ø (mm)	
363 350	350	2" gas	60	003630035
363 450	450	2 1/2" gas	76	003630045
363 600	600	3" gas	90	003630060
363 900	900	5" gas	140	003630090

352U

Adjustable tube flaring tool for copper and light alloy pipes

Ø 5÷16 mm
3/16"÷5/8"



003520101 860 g

186 8-32

Self-locking wrench with automatic take-up device for hexagons, 8 to 32 mm

Ideal for hexagon, Spline, square and Torx® head screws, including damaged screws.

L 260 mm



-  SPLINE®
12 sides
-  Square
-  Torx®
-  Hexagonal
-  70%
rounded bolt



001860008 560 g

1651DGT

Digital vernier made from hardened stainless steel in hard plastic case

- Reading to 0.01 mm
- Screw slider locking
- mm/inch conversion



DIN 862
UNI EN ISO 13385-1

1651DGT/150

A Max 150 mm L 225 mm

016510111 150 g

1651DGT/200

A Max 200 mm L 285 mm

016510112 425 g

1650

Sliding gauge made from hardened stainless steel

- Reading to 0.05 mm
- Spring locking

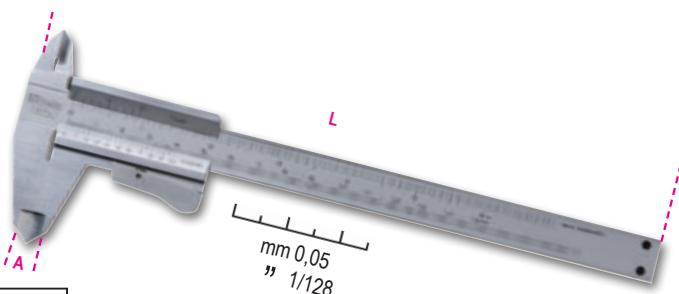

DIN 862
UNI EN ISO 13385-1

1650/150

A Max 150 mm L 235 mm

016500001 170 g

1650/200

A Max 200 mm L 290 mm

016500002 230 g

1691BM

Measuring tapes shock-resistant bimaterial ABS casings, steel tapes, precision class: II

	L (m)	S(mm)	g	
1691BM/5	5	25	275	016910205
1691BM/8	8	32	490	016910208
1691BM/10	10	32	630	016910210

437P

Thread dresser, for repairing internal and external, right-hand and left-hand threads P 0,80÷3,00 mm

New item



004370003 122 g

437U/09

Assortment for repairing damaged threads

- M5X0,8
- M6X1,0
- M8X1,25
- M10X1,5
- M12X1,75



004370550 2 kg

370x230x55 mm

1726BM

Hacksaw frame with quick release blade attachment system

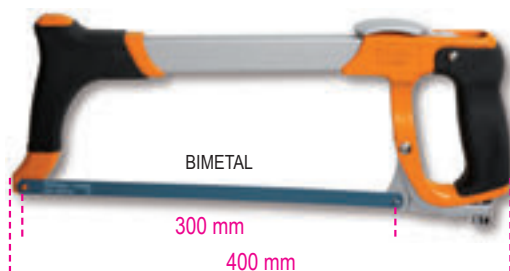

017260050 800 g



1606T

Crimping pliers for tubular terminals, 4-sided crimping



016060005 450 g

0,1÷10 mm²

1149F

Front wire stripping pliers with cutting blade, self-adjusting



011490010 500 g

0,2÷6 mm²

1760/RMS

Industrial digital multimeter accurate and sturdy, in a 6-mm co-moulded shell, with antislip, shockproof outer rubber part



- Water protection IP67
- Protection up to 1000V
- Tested for accidental falls up to 2 m
- Protected inlets • Autoranging
- Large direct reading display, backlit, blue
- K type temperature probe (included)
- Self-power down
- Rubber terminal base for enhanced operating comfort
- Double insulated terminals, 1000V, 1 m long
- Supplied in a soft case
- CAT IV 600V/ CAT III 1000V
- Actual effective value TRUE RMS



	Measuring range	Base accuracy
AC/DC voltage	110mV – 600V ±0.8%	- ±2% rdg
AC/DC current	110µA – 10A ±1.5%	- ±2% rdg
Resistance	110Ω – 40MΩ ±1.2%	- ±2.5% rdg
Capacity	11nF – 40mF ±5%	- ±10% rdg (up to 11mF)
Frequency	1100Hz – 110 MHz ±1.2%	- ±1.5% rdg
Temperature	-32°C – +1000°C ±3%	- ±5% rdg
Diode test	3V DC ±10% rdg	
Continuity test	<30 Ω	

017600020 800 g



1609B

Mechanical crimping pliers

- For noninsulated copper terminals, 10÷120 mm²
- Antislip rubber handle
- Internal "H" section pin for unparallelled punch smoothness
- Made from burnished steel

L 600 mm



10÷120 mm²

016090101 4,2 kg



1256/C36-2

Bi-material microscrewdriver with 36 interchangeable 4-mm bits and magnetic extension

	1256TX	⊗	T3-T4-T5-T6-T7-T8-T9-T10-T15
	1256RTX	⊗	T6-T7-T8-T9-T10
	1256LP	⦿	0,8-1,2-1,5-1,8-2-2,5-3-3,5-4 mm
	1256PE	⦿	0,7-0,9-1,3-1,5-2 mm
	1256PH	⊕	PH000-PH00-PH0-PH1
	1256PZ	⊕	PZ000-PZ00-PZ0-PZ1
	1256/20		
	1256/30		

130x60x35 mm



012560100 200 g

1740B 330

Compact heavy-duty riveting pliers

- Optimized lever ratio for increased compactness and handiness.
- 3 jaws lock rivet for a perfect grip.
- Adjustable head for pulling rivet by 2 to 5 leg movements.

2,4÷6,4 mm steel



**3 jaws:
improved
rivet grip**

017400330 1 kg



*With
stem tank*

1741B

Riveting pliers supplied with 4 interchangeable nozzles

017410000 600 g



1741U

Ultra compact riveting pliers with adjustable force with 4 interchangeable nozzles



**3 jaws:
enhanced
rivet grip**

017410450 450 g



L 200 mm

1749AC

High thrust gun for chemical binders



230 mm

STANDARD

Ø 50 mm

017490005 1 kg

1749A

Bonding gun, professional model aluminium tube



017490010 803 g

1750

Lever operated grease guns, 500 cc



550 Bar

017500500 1,2 kg



7042LCD

Auto-darkening LCD mask, for electrode welding; MIG/MAG; TIG and plasma. Solar cells power supply and lithium batteries for outstanding LCD filter life

- Viewing area: 98x43 mm
- Darkening shade: DIN 9-13, externally adjustable
- UV/IR protection
- Light to dark time: 1/25000 s
- Dark to light time: 0.25-1s
- Adjustable darkening sensitivity and delay
- Auto on/off
- Grinding feature
- Optimized shape to make it easier to breathe with pulled-down screen



070420001 900 g

1860 160A

DC inverter welding machine for MMA and TIG electrode steel welding. Compact and easy to carry. Arc force, hotstart, anti-sticking and thermostatic protection features



Adjustment current:	5÷160A
Power supply:	1 x 230V
Use factor (40°C):	30% - 160 A 60% - 130 A 100% - 110 A
Delayed fuse:	25A
Protection:	IP23S
Use with generators:	✓
Use with generators:	25 mm ²
Usable electrodes:	Ø 1.5 - 4 mm rutile, basic, stainless steel, cast iron etc.

018600006 7,8 kg

1860SQ

Magnetic square, 45°/90°

- Ideal for locking tubular or flat parts
- 40 kg magnetic force
- No battery required, ON/OFF effect obtained by tilting interior magnets
- Easier chip removal with magnets in OFF position



018600210 700 g



1852R1750

Portable induction heater

- heats and loosens stubborn bolts, hubs and bearings without using flames
- allows any type of ferromagnetic metal to be heated

Maximum safety without using flames



480x370x130 mm

Technical data:

- input voltage: 230V AC, 50/60 Hz
- input current: max. 7.5 A
- power: max. 1.75 kW

BENEFITS

- 1 - **Time saving:** quick, extremely accurate heating
- 2 - **Fire safety:** does not produce flames, maximum operator safety
- 3 - **Functional:** can be used with one hand, and coils can be easily interchanged

FIELDS OF APPLICATION

- Automotive industry
- Industrial maintenance
- Aviation industry
- Naval industry
- Petrochemical industry

Standard equipment:

- two front attachable coils, Ø 19 and 26 mm, for loosening nuts 1
- one flat coil for heating surfaces 3
- one flexible coil, 800 mm long 2
- supplied in plastic case

018520175

4,5 kg

1827F

Butane gas soldering iron

- 35 g tank
- three interchangeable nozzles: 550 °C; 1000 °C; 1300 °C
- supplied with a stand in hard case



For deforming plastics and unlocking metal parts



018270200

1,5 kg

1870

Solid and fluid vacuum cleaner, 20 l

Technical data:

voltage:	230/240 V
frequency:	50/60 Hz
max. power:	1200 W
airflow rate:	58 l/sec.
max. suction power:	190 mbar
max. drum capacity:	20 l
acoustic emissions:	<70 dB(A)
cable length	5 m

Equipped with:

corrugated hose:	✓
hard tubes:	✓
multiuse brush:	✓
flat nozzle:	✓
rubber fitting inside Ø	x
FILTERING SYSTEMS	
air filter cartridge:	✓
anti-foam filter:	✓
bag:	x

Bag not included



Non-marking wheels



018700020

6,9 kg



1838COB

Compact rechargeable inspection lamp with ultra-brightness LED. Lithium polymer battery

- Compact body made of antislip rubber
- Swinging hook
- Magnetic base can be rotated 180 degrees
- With charger 100-240Vac / 50-60Hz
- 100/200 lumens - spot 75 lumens
- Operating range: 5 / 2.5 hours
- IP65



018380010 200 g



120x59x25 mm

1836A

LED headlamp, dual brightness, with contactless ON/OFF sensor

- 120/65 lumens
- IP54
- Batteries: 3xAAA included

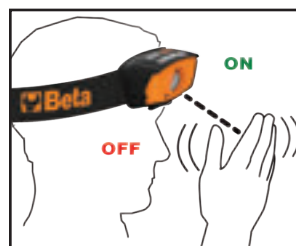

018360050 215 g

1834P...

High-brightness LED torch, made of sturdy

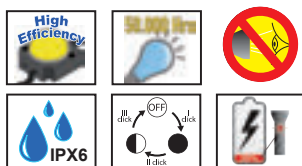

1834P XL

1350 LUMEN
3xD Not included
018340330 300 g

1834P L

500 LUMEN
1xAA 2xAA 3xAAA
018340325 270 g

1834P M

350 LUMEN
1xAAA 2xAAA 3xAAA
018340320 120 g

1834P S

300 LUMEN
2xAA
018340310 56 g



Matt finish

1838SLR

Rechargeable, articulated LED inspection lamp

- Compact front LED (200 lumens) and head LED (100 lumens) for inspections
- Lighting body no more than 9 mm thick
- Operating range: 5/2.5 hours (depending on light level setting)
- With USB charger
- With metal hook and magnet
- IP80



Compact and versatile

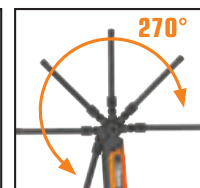
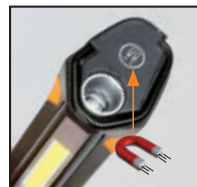

018380201 200 g



242x41x30 mm

1838/11LED

Rechargeable inspection lamp with ultra-high brightness LEDs, lithium polymer battery

- Compact body made of antislip rubber
- With charging station, 110-230Vac
- With multidirectional head LED



Even more compact and brighter



With head LED



Swinging hook



018380111 700 g



1842LED/ABM

Lamp with ultra-high brightness LEDs, 12-24 V; AC-DC

- Compact body made of antislip rubber
- Easy-to-replace front glass
- Swinging hook
- With multi-directional head LED light



018420311 1,1 kg



1846LED/BM

Automatic cable reel with LED inspection lamp, 100-240 Vac

- With 230/24 V safety transformer
- Max. 25 W



018460301 5,8 kg



1848

Automatic cable reel with Schuko type socket

- Max. 1600 W with unwound cable
- Max. 1200 W with wound cable
- Crush-resistant rubber cable H07 - 3x1.5 mm² - 15m



018480015 5,2 kg



1837C

Rechargeable LED spotlight for building yards

- 3 brightness settings
- battery charger:
input: 100-240V AC - 50/60Hz;
output: 15V 1.5A
- charging time: 4 hours
- 3-LED charge indicator
- can rotate up to 180°
- IP65
- IK07



New item



1837C/2100

500/1000/2100 lumen



220x225x70 mm

018370210 1,1 kg



1837C/4300

1100/2200/4300 lumen



266x236,6x59 mm

018370430 1,3 kg

1838FLASH

Rechargeable, ultracompact spotlight, designed to offer the best possible solution for each use

- IP65 - without external power supply
- Dual brightness: 650 / 300 lumens
- Lithium polymer battery 7.4 V 4000 mAh



1837S

Telescoping tripod for worklight

- Made of metal
- Adjustable height:
70÷155 cm

New item

*Compatible with items
1837C and 1838FLASH*

018370500 2,4 kg



ABUNDANT READY LIGHTING:

with a maximum lighting capacity of 720 lumens, and running on both battery and cable, it is always ready to use

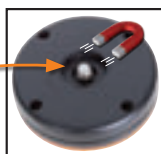

018380300 820 g



85x100x155 mm

1778S0S

Car service knife with window breaking hammer and seat belt cutter features, in case

- with clip and fabric wallet with loop
- anodized aluminium handle
- safety blade lock

017780080 184 g



1772M

Safety utility knife with retractable blade, supplied with 3 blades

- Blade retracts through an automatic spring mechanism
- die-cast alloy body
- staple remover built into handle

*Adjustable cutting
depth \varnothing 25 mm*

017720040 160 g



1771HD

New item

Utility knife, 18 mm, supplied with 6 blades

- Automatic blade change
- Screw blade locking system

017710100 170 g



1128FXS

Electrician's scissors with graduated milling profiles, straight stainless steel blades, with microteeth, cable cutting groove and crimping pliers for tube terminals

- Articulated belt hook case
- Bimaterial handles
- Anti-loose pin
- Profile and mill: designed to enlarge holes on plastic, from 13 to 21 mm



011280095

80 g

New item

Patented



A new perspective

To redesign our electrician's scissors, we observed users' daily work. We have made it into a universal tool, incorporating the 4 main features into one object.

CUTTING

quick and sharp, for cables up to 50 mm², with a cable cutting groove and a microtoothed blade, for improved hold.

STRIPPING

the sensitive anti-loosening pin allows even the thinnest cables to be accurately stripped.

CRIMPING

safe and durable, for tube terminals.

COUNTERSINKING

the unique milling profile allows the holes in pull boxes to be countersunk accurately and neatly.

1128FX

Electrician's scissors, straight stainless steel blades, with microteeth, cable cutting groove and crimping pliers for tube terminals

- Articulated belt hook case
- Bimaterial handles
- Anti-loose pin

011280090

80 g

With cable cutting and crimping function



1128BAX

Double-acting electricians' scissors, with milling profiles in DLC-coated stainless steel

- High blade surface hardness (resistance to abrasion and wear)
- Low coefficient of friction (smoothness and anti-adherence)
- With articulated plastic case



**+hardness
-coefficient
of friction**

011280088

160 g

Patented



Profile and mill: designed to enlarge holes on plastic, from 13 mm to 25 mm.



1273MQ/D6



Set of 6 screwdrivers

1274MQ ● 3x100-4x100-5,5x125 mm
1272MQ ⊕ PH0x60-PH1x80-PH2x100 mm

1000 V

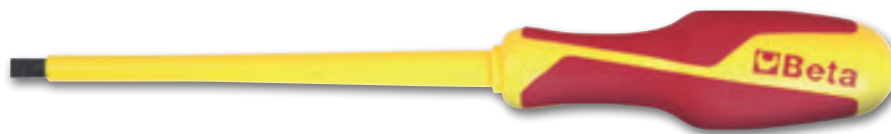

012730851 500 g

1273MQ/F-D6



Set of 6 slim screwdrivers

1274MQ/F ● 0.5x3,5x100 - 0.8x4,5x100 -
1x5,5x125 - 1.2x6,5x150 mm
1272MQ/F ⊕ PH1x4.5x80- PH2x6x100 mm



1000 V



012730406 500 g

1760/OHM

Multimeter/megohmmeter for high voltage insulation testing. TRUE RMS indicator



CAT. IV 600V
CAT. III 1000V

	Measuring range	Base accuracy
AC/DC voltage:	50mV - 1000V	±0.06% - ±0.1% rdg
AC/DC current:	0.01µA - 10A	±0.5% - ±1% rdg
Resistance:	0.01Ω - 50MΩ	±0.2% - ±2% rdg
Meg OHM:	0.01 - 5000MΩ	±4% rdg. max current 1mA
Capacity:	5nF - 10mF	±1.5% - ±3% rdg
Frequency:	50Hz - 100 MHz	±0.02% - ±0.1% rdg
Temperature:	-50°C - +1350°C	±0.5% rdg
Diode test:	3V dc	
Continuity test:	<30 Ω	

017600025 500 g

1169MQ/D2

Assortment of insulated combination pliers and insulated diagonal cutting nippers

1000 V



1150MQ 180 mm

1082MQ 160 mm



011690143 600 g

2115P L-MQ32

Assortment of 32 insulated tools for hybrid cars, in plastic tool box with soft thermoformed tray



021150332

6,7 kg

Quantity/Description

1	1/2" reversible ratchet	Beta N.	920MQ/55A
1	single ring wrenches 10-12 mm		89MQ
1	magnetic bit holder, insulated 1/4"		850MQ
10	set of 10 bits with magnetic bit holder ○ T7-T8-T9-T10-T15-T20-T25-T27-T30-T40		860TX/A10
7	hexagon sockets ○ 8-10-12-13-14-17-19 mm		920MQ/A
1	1/2" square drive extension bar 125mm		920MQ/21
1	1/2" square drive extension bar 250mm		920MQ/22
1	slip joint pliers, boxed joint 250mm		1048MQ/250
1	combination pliers 1000V = 180mm		1150MQ
1	extra-long bent flat nose pliers = 160mm		1164MQ/160
2	screwdrivers for cross head Phillips® screws, 1000V ⦿ 4.5X80-6X100mm		1272MQ
3	screwdrivers for headless slotted screws, 1000V ● 3X100-4X100-5.5X125		1274MQ
1	insulating gloves, made from latex G2		1995MQ/G2
1	tool box, long series, made from plastic		CP15L

5988VHB-MQ

Assortment of 66 insulated tools, 1000V, in soft foam trays

New item



M49

24



M108

27



M161

15

Quantity/Description

12	single open end wrenches, 1000V 7-8-10-11-12-13-14-15-16-17-19-22 mm	Beta N.	52MQ
12	single ring wrenches 7-8-10-11-12-13-14-15-16-17-19-22 mm		89MQ
4	socket drivers for hexagon screws ○ 4-5-6-8 mm		910MQ/PE
11	bi-hex sockets ○ 7-8-10-11-12-13-14-15-16-17-19 mm		910MQ/B
6	socket drivers for Torx® head screws ○ T15-T20-T25-T27-T30-T40		910MQ/TX
2	socket drivers with XZN® profile ○ 8-10 mm		910MQ/XZN
1	3/8" drive extension 125 mm		910MQ/21
1	3/8" drive extension 250 mm		910MQ/22

Quantity/Description

1	3/8" drive, T-handle	Beta N.	910MQ/T
1	3/8" drive reversible ratchet		910MQ/55
1	electrician's scissors		1128MQ
1	slip joint pliers, boxed joint 250 mm		1048MQ
1	diagonal cutting nippers 1000V < 160 mm		1082MQ
1	combination pliers 1000V = 180 mm		1150MQ
1	extra long flat nose pliers = 160 mm		1162MQ
1	extra-long bent flat nose pliers = 160 mm		1164MQ
4	screwdrivers for cross head Phillips® screws, 1000V ⦿ PH0x60 - PH1x80 - PH2x100 - PH3x150 mm		1272MQ
4	screwdrivers for headless slotted screws, 1000V ● 2,5x75 - 3x100 - 4x100 - 5,5x125 mm		1274MQ
1	cable stripping knife, insulated		1777MQ/U

059880400

6,2 kg



7103K4

New item

Barrier kit for hybrid or electric vehicles waiting to be repaired, comprised of 4 90 cm-high posts and 1 25 m long plastic chain

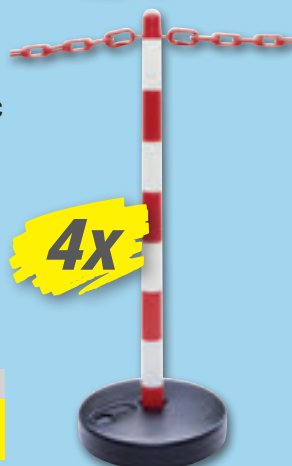

4x

071030001

7109/S7

New item

Set of 7 electrical hazard signs, aluminium frame



071090107

115 mm

1500N

Universal pullers with 2 sliding legs

	A min (mm)	A max (mm)	L (mm)	
1500N/0	18	65	70	015000600
1500N/1	23	70	100	015000601
1500N/2	23	100	100	015000602
1500N/3	35	140	150	015000603
1500N/4	35	190	150	015000604
1500N/5	43	250	205	015000605
1500N/6	43	320	205	015000606

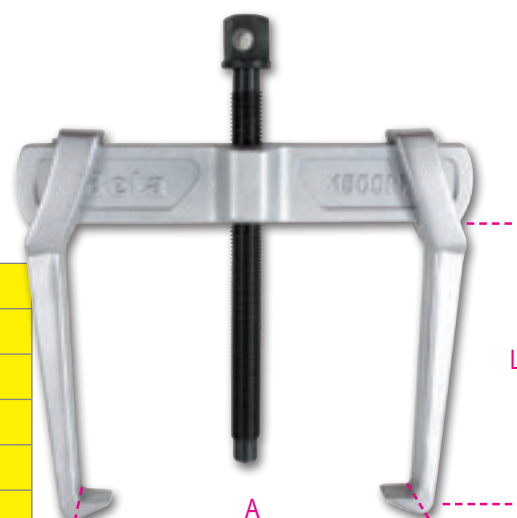

1430/S8

Set of 8 tapered extractors for broken screws and studs, made from hardened steel in plastic case

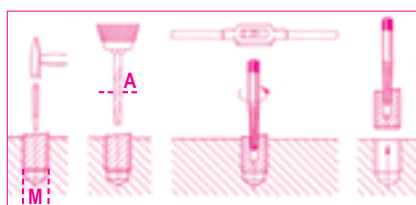

	M	A mm
1430/1	3÷6	2,5
1430/2	6÷8	3,0
1430/3	8÷11	4,5
1430/4	11÷14	6,0
1430/5	14÷18	8,0
1430/6	18÷24	11,0
1430/7	24÷33	14,0
1430/8	33÷50	21,0

014300108 745 g



1545/C5M

Puller 1542/1 with 5 extractors 1544, in metal case



265x180x45 mm

015450011 2,4 kg

	A mm	C mm
1544/1	9÷12	0,80
1544/2	13÷17	1,15
1544/3	16÷21	1,70
1544/4	20÷25	1,65
1544/5	25÷30	2,00

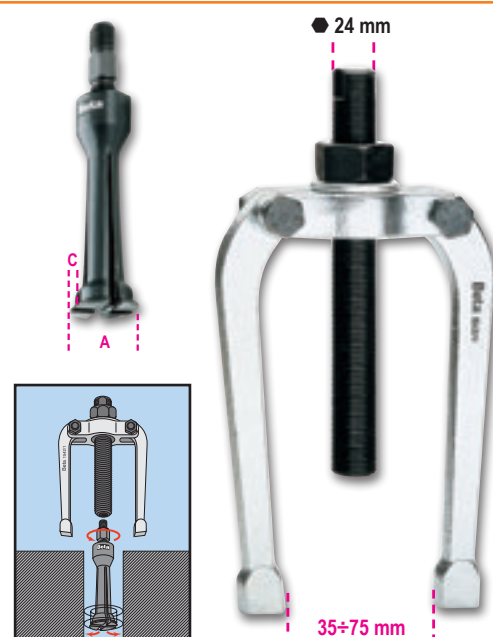

3050/600

New item

Electro-hydraulic motorcycle jack, 600 kg

Technical specifications

- Electrical, mechanical and hydraulic safety devices
- Capacity: 600 kg
- Integrated electro-hydraulic unit: 230V - 50 Hz
- Hydraulic pump
- Controlled downward speed
- Safety fuses for protection in case of cable cuts
- control push button panel
- CE-certified, TÜV-approved



198 kg

3050

030500201

030500202

030500203

9562T3

New item

Garage mat, 300x160 cm

- Particularly suitable for use under motorcycle jacks
- Protects floor from oil and petrol leaks, environmentally friendly
- Easy to clean, anti-skid, rubber-coated bottom



095620300

4,8 kg

3040C

New item

Rear motorcycle stand, adjustable

- Matt black lacquer
- 4 thermoplastic rubber wheels
- Includes V-shaped sliders, pair
- Includes L-shaped sliders, pair



030400002

4,8 kg

3043C

New item

Motorcycle stand with left single arm

- Matt black lacquer
- 4 thermoplastic rubber wheels



030430002

6,5 kg

3041C

New item

Front motorcycle stand, adjustable

- Matt black lacquer
- 4 thermoplastic rubber wheels
- Includes roller sliders, pair
- Includes cone-shaped sliders, pair



030410002

5 kg



1498/16A

Electronic multipurpose battery charger, 12-24V

- backlit graphic display
- max. charging current: 16A, continuous
- charging and charge maintenance
- protected against polarity reversal and short circuits
- 9 charging steps
- floating system
- SHOW ROOM function (13.8V - 12A)
- SUPPLY function (14V - 12A)
- memory saving function (13.8V - 12A)
- battery recovery function
- clamp holder
- reclining hook fastening
- supplied accessories: cable with clamp, cable with eyelets



New item

TECHNICAL DATA

Power supply: 220-240V
 Power: 240W
 Charging current: 4-16A
 Battery types: Agm - Wet - Lithium (LiFePo4)

Charging capacity: 5-360Ah
 Maintenance capacity: 5-550Ah
 Output voltage: 12-24V
 Minimum battery voltage: 0.8V
 Degree of protection: IP20

014980126 2 kg

961P6

Electronic videoscope with flexible probe

Allows videos or individual images to be directly recorded on instrument



- Supports SD cards (8 GB)
- Supports flash memories (8 GB)
- Internal memory: 128M
- TV-OUT feature
- Supports video formats (MP4, AVI, 3GP)
- 4 LEDs
- Power supplied by USB port (built-in battery)



SPECIFICATIONS

- Sensor pixels: 640x480
- Maximum resolution: 320x240
- Probe length: 1 m
- Camera diameter: 6 mm
- Video formats: MPEG4, 3GP, AVI, ASF.
- Photo formats: JPEG
- Shooting angle: 0÷180°
- Data output: USB cable and SD card
- Power supply: 3.7V 2000 mAh battery

009610000 2 kg

1498/8A

Electronic car / commercial vehicle battery charger, 12 V

Protected against polarity reversal and short circuits

- Digital backlit display
- Pull-back fixing hook
- Rated current (min-max):
 1-4 A (1498/4A); 2-8 A (1498/8A)
- Battery capacity: 4-80Ah (1498/4A); 5-160Ah (1498/8A)
- Power supply function 13,8V-5A

Power supply voltage	220V-240V
Frequency	50-60 Hz
Rated current (Min-Max)	2-8 Amp
Battery voltage	12V
Battery capacity	5Ah-160Ah
Degree of protection	IP65
Battery type	Wet-Gel-Dry-AGM

014980108 1,2 kg



1760PA/AC-DC

Amperometric clamp and digital multimeter

SPECIFICATIONS

DC voltage: 0.1mV ÷ 600V
 AC voltage: 0.1mV ÷ 600V
 AC current: 0.01A ÷ 1000A
 DC current: 0.01A ÷ 1000A
 Resistance: 0.1Ω ÷ 40MΩ
 Capacity: 0.001nF ÷ 40 μF
 Frequency: 0.001kHz ÷ 4kHz
 Temperature: -40°C ÷ 1000 °C
 -40°F ÷ 1832°F



017600000 660 g

1760/IR500

New item

Digital infrared thermometer with dual laser aiming system

TECHNICAL DATA

Temperature range: $-50 \div 500 \text{ }^\circ\text{C}$ ($-22 \div +932 \text{ }^\circ\text{F}$)
 Display resolution: $0.1 \text{ }^\circ\text{C}$ ($0,1 \text{ }^\circ\text{F}$)
 Emissivity: $0.1 \div 1$ adjustable
 Accuracy: $-50 \text{ }^\circ\text{C} \div +20 \text{ }^\circ\text{C}$ ($\pm 3 \text{ }^\circ\text{C}$);
 $20 \div 500 \text{ }^\circ\text{C}$ ($\pm 2\%$ or $2 \text{ }^\circ\text{C}$)
 Optical resolution (D:S): 12:1
 Auto power off: ca. 10 seconds
 Operating temperature: $0 \text{ }^\circ\text{C} \div 50 \text{ }^\circ\text{C}$
 Storage temperature: $-20 \text{ }^\circ\text{C} \div 60 \text{ }^\circ\text{C}$
 Power supply: 1 9V battery

500°C



017600350

350 g

1497/C23

Assortment of 23 tools for releasing electrical connectors



014970200

1,5 kg

1498TB/12-24

Digital battery tester, 12V, and starting/charging system analyzer, 12-24V

- allows the following to be tested: battery, alternator (smart and normal) and starter, diode ripple and chassis test
- fitted with software for printing test from PC
- compact, shockproof frame
- complete with input for connecting a removable mini printer (optional accessory, Beta 1498ST/TB)



Backlit display



10 language software

Applications	- 12V battery test - Alternator charge test, 12-24V - Starter test
Operating range	100-2000 CCA
Reference standards	CCA,SAE,DIN,EN,IEC,JIS
Supported batteries	PB, WET, GEL, AGM, AGM FLAT, EFB
Voltmeter	9V-36V
Cable length	1600 mm
Languages	Italian, English, French, German, Spanish, Polish, Romanian, Dutch, Swedish and Finnish
Accessories included	USB cable and software

014980401

1,5 kg



435x320x100 mm





1498LT/12



Portable high-performance starter, ultralightweight
Includes memory save



4000A

Weighs no more than 2.5 kg!

Operating voltage	12V
Continuous amperage	800A
Maximum pickup amperage	2000A
Peak amperage	4000A
Cable length	500 mm
Battery type	4 celle LifePo4
Memory saving function	Si
Dimensions:	260x135x72 mm
Complete with charging power supply	12 V 1,3A



014980012 3,4 kg



1498/24



Portable car and commercial vehicle starter, 12-24V

- Pickup current: 4200A (12V) - 2100A (24V)
- Sealed lead acid battery, solid electrolyte (AGM) type



014980490 17 kg



1498MN/12



Multipurpose portable starter

- Motor vehicle starting with 12-volt battery (diesel and petrol engines up to 2,000 cc)
- Charging of tablets, mobile phones and electronic devices in general
- Multi-use LED torch



Pickup current	600A
Battery type	5V 1A-2A
Starting output	12 Volt

014980000 542 g



240x185x60 mm



1498/40A



Multipurpose battery charger starter, 12-24V wheeled

- Specific WET-SPIRAL/GEL-AGM charging cycles
- Electronic control and protection system
- Battery desulfurization and recovery function
- Supply function
- Also suitable for Start&Stop batteries



**2 in 1
battery charger
+ starter**



Power supply:	230V
Output voltage:	12-24V
Charging current:	1-40A
Starting current:	350A max cc
Charging capacity:	4-450Ah

014980140 8,5 kg

800 mm
280 mm
300 mm

Can be used as a mobile workstation for diagnostic tools, laptops, testers and battery chargers

- Painted sheet metal frame: unparalleled firmness and sturdiness
- Ergonomic handle
- 2 fixed rear castors Ø 160 mm
- 2 steering front castors Ø 125 mm (one with brake)

CA49-G

Multi-purpose trolley with door, empty

049000112 36,5 kg

CX49-G

Multi-purpose trolley, empty

049000102 36 kg



2-level top

2 central shelves with adjustable position and 1 fixed low shelf



Pull-out drawer for housing a mini keyboard



4 useful side cable reels made of plastic



2 useful side containers



1 paper holder



1099 mm
460 mm
435 mm

1897

New item

Professional bench sander

The cabin is equipped with the following:

- loading door with magnet closure
- perforated sheet metal top
- standard connection for vacuum cleaners, Ø 36 mm
- protective polycarbonate viewing window, 6 mm
- LED lamp
- pneumatic circuit (compressed air inlet)
- sanding gun with trigger operation



MADE IN ITALY

018970066 38 kg

Useful dimensions of cabin	600x520x320 mm
Overall dimensions	660x530x500 mm
Worktop	perforated sheet metal
Lighting	LED
Air consumption	340 l/min at 7 atm
Power supply	220 V - 50 Hz

1897/KSA

New item

Bench sander item 1897, complete with vacuum cleaner item 1871M/AS



60 l/s
35 l

M class

018970660 49 kg

1897/CRB

New item

Corundum for sander 1897 in 25 kg bag



018970101 25 kg

1897/MV

New item

Glass microspheres for sander 1897 in 25 kg bag



018970103 25 kg

1897/G

New item

Garnet for sander 1897 in 25 kg bag



018970104 25 kg



1465

New item

Engine efficiency tester

Allows endothermic engine compression to be tested within just a few seconds, without requiring connection to engine, taking power from vehicle battery, through a dedicated software.

Takes just a few seconds to test compression!

TECHNICAL DATA

Operating voltage: 12V DC (vehicle battery)

Dimensions: 140x75x30 mm

Clamp cable length: 1300 mm



Step 1	Calculating engine rpm
Step 2	Testing battery voltage trend during each revolution
Step 3	Displaying absorbed power and compression calculated through starter operation for each piston
Step 4	Testing battery charge and efficiency

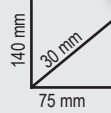
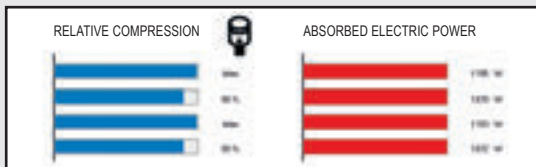

014650010 365 g

MADE IN ITALY

1760/RSE

New item

Signal detector

Allows power supply of parts to be tested, including

- Common rail electro-injectors
- Petrol/LPG electro-injectors
- Piezoelectric injectors
- Flow regulating solenoid valves
- EGR solenoid valves and coils



Performing diagnosis of individual parts of electric system only requires probe to be brought near part being tested.

In systems with electromechanical/electronic parts controlled by a control unit, this tool makes it possible to check whether:

- Control unit is being supplied with power and is performing its control function
- Cables connecting control unit to part is efficient
- Part being tested has not being disconnected
- Part has not short-circuited
- Part is operating electronically

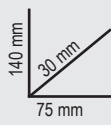

017600170 365 g

MADE IN ITALY

1464T

Digital pressure and compression tester



SPECIFICATIONS

- 5" touch screen display
- rechargeable polymer lithium battery
- complete with 80 bar sensor (for low pressure) and USB cable

014640050

1,1 kg

1464PB



Set of 9 connectors for testing fuel low pressure (for use with item 1464T)

Quick connectors to tester 1464T allow fuel low pressure in diesel and petrol engines to be quickly checked



530x440x120 mm

014640700

3,8 kg

1464IC



Set of dummy injectors and dummy glow plugs for item 1464T

Makes it possible to connect to the engine to check compression in diesel engines with digital tester 1464T.

- 22 dummy glow plugs
- 5 dummy injectors
- 1 universal dummy injector kit for trucks, marine engines and agricultural machines



014640350

4,5 kg

559x312x50 mm

960AD/TP2



Set of adaptors for item 1464T

- Dummy injectors
- Dummy glow plugs
- Spark plug adaptors
- Oil cap adaptors
- Petrol injection couplers
- Set of spare gaskets



430x310x50 mm

009600510

3,7 kg

1464AP



Set for testing high pressure system in common rail diesel engines, with item 1464T

- High pressure pipe set
- Fittings
- 2,000 bar sensor



430x310x50 mm

014640450

1,8 kg





1464VD

New item

Vacuum testing set for item 1464T

For measuring and storing maximum vacuum value
Supplied with:

- 800 mbar sensor
- 6 and 8 mm adaptors
- 3-m-long RJ45 cable

TECHNICAL DATA

Vacuum test: 0÷800 mbar
Resolution: 1 mbar
Maximum value storage



240x210x50 mm

014640570 317 g



1464FAP

New item

Set for testing diesel particulate filter (DPF) pressure for item 1464T

Supplied with:

- 500 mbar sensor
- 8 mm adaptor with quick coupling and T fitting
- 3-m-long RJ45 cable

TECHNICAL DATA

Pressure test: 0÷500 mbar
Resolution: 1 mbar



240x210x50 mm

014640610 328 g



1464ADB

New item

Set for testing AdBlue® system pressure for item 1464T

Supplied with adaptors for use with 80-bar standard sensor supplied with item 1464T

240x210x50 mm

014640620 237 g



1880ADB

New item

Rotary AdBlue® pump

- 5 litres supplied every twenty turns
- drum extensions up to 1.20 m
- 1 fine-pitch drum coupling, fine pitch
- 1 coarse-pitch drum coupling

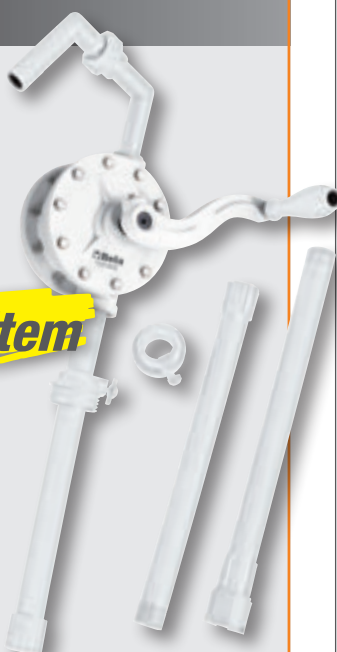

018800101 1,95 kg

1759HD/3

Cooling system seal testing and circuit filling tools

Make it possible to check circuit (pipes, joints, pumps, radiators) for leaks under pressure and quickly fill circuit, avoiding air bubble formation

600x500x140 mm

017590063 6,8 kg



960KPC 14^{PP}

Reversible impulse extractor with adjustable torque for glow plugs

- Pneumatic extractor with adjustable torque and special sockets allow jammed glow plugs to be unscrewed, thereby minimizing damage risk
- 5 1/4" impact sockets, long series, specially designed for glow plugs: 8-9-10-11-12 mm, 2 extensions and 1 articulated joint
- 4 adjustable driving torques: 10-20-30-40 Nm
- Right-hand and left-hand adjustment



009600780 2,9 kg

420x185x60 mm

960EPC/L

Set of tools for removing glow plug electrode face M8x1 - M9x1 - M10x1 - M10x1,25

Allows glow plug tip to be removed when breaks occur during disassembly and head remains stuck in cylinder.

Long version

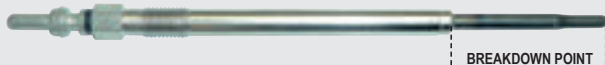

BREAKDOWN POINT

New item



009600890 2 kg

960KC-M8/M9/M10

Assortment of tools for removing broken or damaged glow plugs

For spark plugs with threads M8-M9-M10



009600801 2,5 kg

380x290x50 mm

1462/EI

Universal vibration tool for injector removal

- Helps to fully remove jammed injectors from their housings, without damaging cylinder heads and without breaking injectors
- Can be used with any injector removal set, with or without hammer face
- Tool acts directly on removal tie rod, which is coupled with injector, through vibrations and pulses
- Control valve allows vibration intensity to be adjusted to type of work to be carried out

COMPONENT PARTS

- 1 adapter for inclined grip
- 1 inclined adapter
- 1 adapter for orthogonal grip
- 2 screws
- 1 pneumatic valve



New item



014620240 2,2 kg





1438EVO

Universal clutch aligning kit

Kit contents:

- flywheel alignment bushings
ø 10-12-14-15-16-17-19-25-27-30 mm
- 1 clutch cover aligner
- 2 clutch disc alignment cones
- 3 threaded guide pins
- 2 expansion aligners
ø 15÷19 mm
ø 20÷27 mm

Component parts made entirely from metal

New item



014380011 1,9 kg

290x200x60 mm

960/C6

3/8" female drive hexagon sockets for removing/installing exhaust gas temperature sensors

Kit contents:

- 3 short sizes, 13, 14, 17 mm
- 3 long sizes, 13, 14, 17 mm

New item

High strength



009600055 800 g

1462/KI

Assortment of common rail diesel injector pullers

Allows DELPHI-BOSCH-SIEMENS-DENSO injectors to be removed

- Mechanical and hydraulic operation
- Includes one 12-t hydraulic jack
- Can be directly used on vehicle with mounted engine
- Numerous adjustment options on head make it possible to work on most engines available

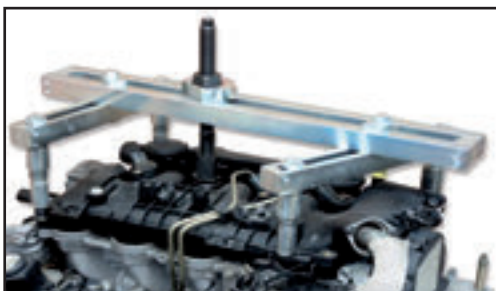

014620235 20 kg



530x470x140 mm

1895G

MADE IN ITALY

New item

Control generator for (petrol and LPG) electro-injectors and solenoid valves

Makes it possible to autonomously test efficiency of such parts as:

- EGR solenoid valves
- Electro-injectors of petrol and LPG engines
- Solenoid valves for variable-geometry turbine adjustment
- Compressors for new-generation air conditioners



BENEFITS

- Makes it possible to understand whether part is working mechanically
- Combined with ultrasonic cleaning tanks, it allows more efficient cleaning of parts, electronically controlling part during washing phase
- Essential for air conditioner testing, to check whether compressor and its control valve are efficient

SPECIFICATIONS

Petrol and LPG injector control:

- Number of outlets: 4
- Test duration: 1-60 s
- Operating time: 5-10 ms
- Impulse frequency range: 1-10 Hz

PWM device control:

- Number of outlets: 1
- Test duration: 1-60 min
- Automatic or manual
- Duty cycle adjustment: 10%-85%
- Signal frequency regulation: 120-250 Hz

Includes 4 connectors with female FASTON terminals
Power supply: 110-220 V

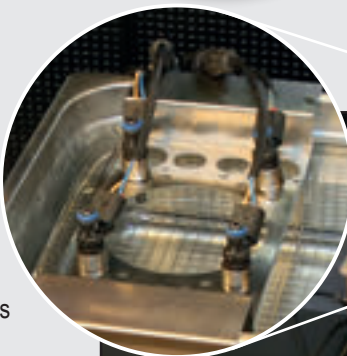

018950800

4 kg



1497/C94

Assortment of 94 car testing connectors
For use with main diagnostic tools

**Complete
with 2 t-taps**



Assortment contents:

- 2 t-taps
- 2 potentiometers
- 2 warning lights
- 2 SRS connectors
- 2 alligator clips
- 2 acicular probes
- 2 prods
- 2 dual banana connectors
- 4 single banana connectors
- 24 flat male terminals 0.6÷6 mm
- 12 round male terminals 1.6÷3.9 mm
- 24 flat female terminals 0.6÷6 mm
- 12 round female terminals 1.6÷3.9 mm

014970300

3 kg

430x390x100 mm



1895

Ultrasonic cleaning tank with special degas function

- Ultrasonic cleaning relies on fluid heating to effectively clean spare parts and metal pieces in general (carburetors, valves etc.)
- Digital display for temperature and cleaning time selection
- Two cleaning modes: "soft" and "normal"
- For normal cleaning, just use water at a temperature of 50/60 °C
- For more accurate cleaning, add non-foaming detergent solutions (type Arexons Fulcron Extra) specific for ultrasonic tanks
- Using the degas mode speeds up air release throughout the tank, thereby improving ultrasonic cleaning efficiency



1895 6

1895 13

1895 27

Tank capacity	6 l	13 l	27 l
Drain tap	✓	✓	✓
Power	150 Watt	300 Watt	500 Watt
Heating power	300 Watt	400 Watt	500 Watt
Temperature range	0+80°C	0+80°C	0+80°C
Cleaning time range	0-99 minutes	0-99 minutes	0-99 minutes
Frequency	40 kHz	40 kHz	40 kHz
Power supply	220/230V	220/230V	220/230V
Dimensions	330x180x310 mm	350x325x320 mm	530x330x380 mm



Ideal for injectors and EGR valves



1895 6

6 l

018950060

8,1 kg

1895 13

13 l

018950130

12,5 kg

1895 27

27 l

018950270

13,5 kg

1895/S

Adjustable support for ultrasonic cleaning tanks 1895

Allows injectors to be correctly placed during washing in ultrasonic cleaning tank

New item

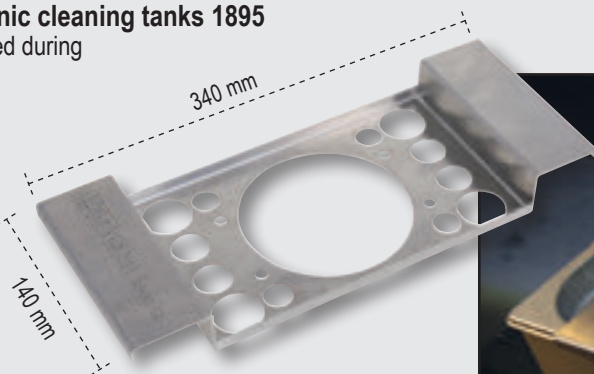

018950501

410 g

1885

MADE IN ITALY

New item

Automatic gearbox maintenance station

Allows entire washing cycle to be safely performed in all automatic transmissions, through a simple, guided procedure. Avoids damage from wear of oil in automatic gearbox, thereby easily and quickly preventing typical malfunctions, including: excessive gearbox noise, jammed gears, abruptly engaged gears, long gear shifting time.

FUNCTIONAL SPECIFICATIONS

- Automatic operation
- Step-by-step guided procedure with integrated database
- Balancing quantity of injected oil with same quantity of exhausted oil, thereby making sure that system always contains proper quantity of oil
- Flow meter for visual inspection of oil quantity
- Printing records of each operation

AUTOMATIC SPECIFICATIONS

- Injecting solvent (optional)
- Washing gearbox system
- Emptying oil out of sump
- Emptying oil out of converter
- Injecting oil into converter

TECHNICAL SPECIFICATIONS

- Power supply: 220 V 50 Hz
- Backlit oil viewers with 2 white light LEDs
- 2 electronic balances
- Electronic balances, resolution +/- 10 g
- Electronic card with backlit graphic display



Database included

Fully automatic

018850010 70 kg

1884

Oil filler tool for manual and automatic gearboxes and differentials

- Complete with 12 adaptors for direct connection
- Fitted with nonreturn valve for leakage-free oil filling
- Delivery: 70 cc per pump shot
- Tank capacity: 7.5 l
- Maximum permissible oil viscosity: SAE 140

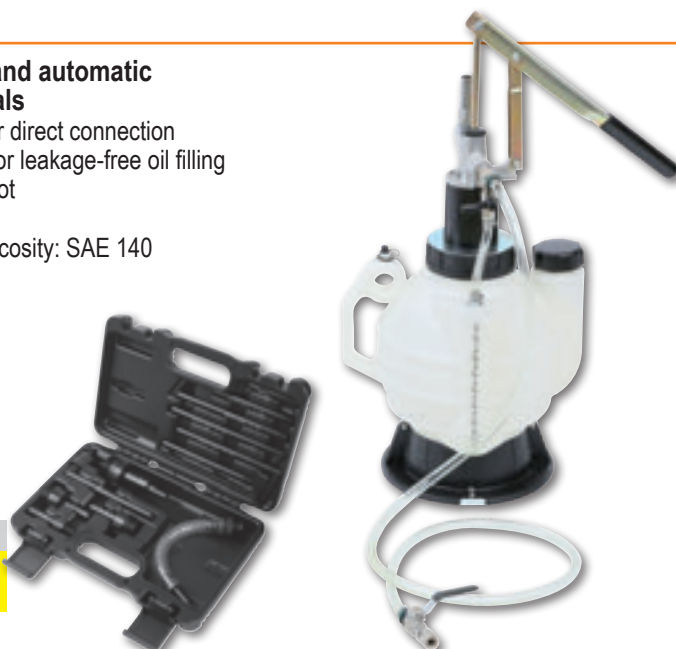

12 ADAPTORS		
FORD		AT-101
UNIVERSAL (Bmw, Honda, Nissan...)		AT-102
VW-AUDI		AT-103
VW-AUDI-PORSCHE		AT-104
VW-AUDI-MINI COOPER		AT-105
MERCEDES		AT-106
DSG		AT-107
VW-AUDI CVT		AT-108
VOLVO		AT-109
TOYOTA-LEXUS		AT-110
SKODA		AT-111
VW Passat/Tiguan <2007		AT-112

018840010 4,8 kg





1893

MADE IN ITALY

New item

Automatic charging station for air conditioners

Fully automatic model, complete with car/lorry database with gas quantities, compressor oil quantities and types, self-diagnosis software for routine maintenance jobs. Database can be updated via software. Machine can be operated in both manual mode (provided it is controlled by a human operator step by step) and in fully automatic mode (without requiring a human operator).

FUNCTIONAL SPECIFICATIONS

- Automatic operation
- Car/lorry database with gas quantities and compressor oil quantities and types
- Automatic gas recovery from pipe
- Compensation of recharged quantity of gas in pipes
- Automatic discharge of noncondensable gases
- Automatic reporting of defects and required maintenance jobs
- Gauges, ø 80 mm
- Digital vacuummeter

TECHNICAL SPECIFICATIONS

- Gas tank: 15 kg
- Vacuum pump: 75 l/min
- Electronic balance: 50 kg
- Electronic card with backlit display
- Recovery rate: 500 rpm
- Power supply: 220 V



Gas R134A

1893/134A

018930001 70 kg

gas tracer R134A (250 ml) included



Gas R1234YF

1893/1234YF

018930012 70 kg

gas tracer R1234YF (250 ml) included



1893TR/CI

Gas tracer

New item



018930903 300 g

1879 6

Manual operation fluid extractor, 6 l

- 3 hard pipes that can be connected to each other
- 1 hose specifically designed for brake oil bleeding

New item



018790000 3,7 kg

Oil drain units

- level indicator
- big diameter pan with breakwater grate; capacity: 12 l
- pneumatic tank emptying through 1.8 m pipe

1877

Exhausted oil drain unit, wheeled, with 90 l tank



018770008 23 kg

1877A

Exhausted oil drain unit / vacuum cleaner, wheeled, with 90 l tank and pre-chamber

- Transparent pre-chamber: capacity 9.5 l
- 1.8-m suction pipe

Standard accessories:

- 1 hard probe, Ø 5x700 mm
- 1 flexible probe, Ø 5x700 mm
- 1 hard probe, Ø 6x600 mm
- 1 flexible probe, Ø 6x700 mm
- 1 flexible probe, Ø 7x700 mm
- 1 flexible probe, Ø 8x700 mm
- adapters for VW, BMW, CITROËN



018770080 29,5 kg

1493/C7

38 mm 16 mm

Self-adjusting oil filter wrench with three arms for right- and left-hand tightening, with interchangeable arms

2 sets of arms:

- 1 set with 20 mm working length
- 1 set with 38 mm working length



Ø mm
50÷100

Antislip diamond finish



014930079 600 g

210x150x50 mm

1493H

38 mm 12 mm

Self-adjusting oil filter wrench with 3 arms, for right and left hand tightening

Knurled jaws

New item

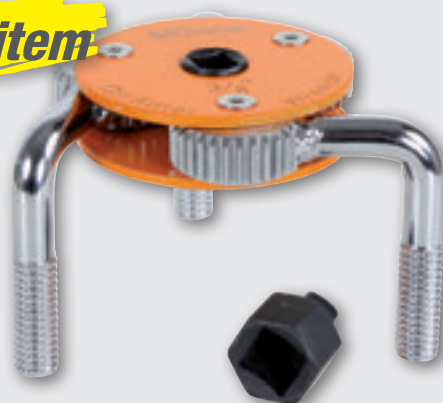

014930077 550 g





1490F 38" 12"

Strap wrenches for filters

New item



Ø Max: 200 mm

014900201 250 g

1491 38" 12"

Adjustable oil filter wrench



Ø min: 65 mm
Ø Max: 110 mm

014910001 450 g

1493VW 12"

Diesel oil filter wrench, for VAG and Volvo cars

New item



014930086 130 g

1494BMW 38"

Special socket for plastic oil drain plugs, for BMW engines

● 10 mm
○ 17 mm

New item



014940315 30 g

1494FPC 38"

Special socket for plastic oil drain plugs, for Ford, Peugeot and Citroën engines

○ 17 mm

New item



014940320 40 g

1494VW/K

Engine oil replacement kit, for VAG cars

Kit contents:

- 1 special socket for plastic oil drain plugs
- 6 plastic oil sump plugs

New item



014940310 120 g

1491A **New item**

Adjustable oil filter pliers

Precision adjustment through rack



Ø min: 55 mm
Ø Max: 140 mm

014910040 620 g

1491T **New item**

Adjustable truck oil filter pliers

Precision adjustment through rack

For use with drier filters



Ø min: 70 mm
Ø Max: 200 mm

014910050 1,5 kg

1758

Self-adapting funnel

Particularly useful for cars with no depth in inlet plugs

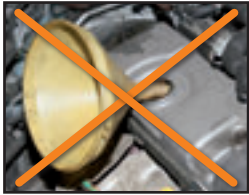

017580020 400 g

1758B

Non-return funnel with quick couplings

Particularly suitable for VAG cars



New item

Non-return

017580030 500 g

1756G

New item

Diesel oil gun capacity: 1.5 l

Can be used to:

- fill diesel oil filters
- fill Cerina tank

Kit contents:

- 2 pipes with female quick couplings for connecting diesel oil pipes
- 2 male quick couplings, made of metal
- 1 cone-shaped adapter for rubber pipes



1500 ml

017560615 850 g

Polypropylene suction guns

- Also suitable for braking system fluid
- Operating temperature: +0 - +50 °C
- NOT suitable for fuel

200 ml

Double EPDM gasket



1756C

017560502 250 g

1500 ml

Double NBR gasket

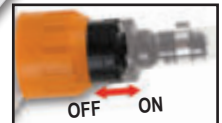

1756D

017560515 690 g





1466/C5

Kit of 5 brake bleeding wrenches

Kit contents:

- 5 wrenches sizes 7-8-9-10-11 mm
- 1 drain hose with check valve

260x170x50 mm

Oil goes into bush



014660100 700 g



1485TC

New item

Tensioning lever for service belts, mounted on Ford, PSA, FCA engines



014850330 680 g

1466L 11

New item

Brake bleeding wrench, 11 mm, long version

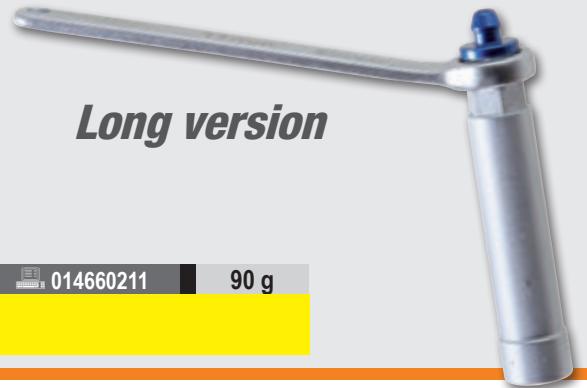

Long version

014660211 90 g

1466TLF

Brake oil recovery tank capacity: 1.5 l

Quick coupler for bleeding pipe Ø 5.5 mm

New item



014660201 300 g

1482D

Quick coupler pliers for fuel pipes, with flexible extension

New item

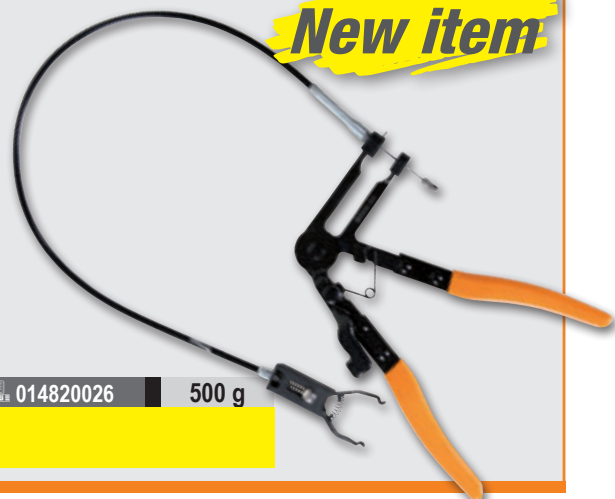

014820026 500 g

1472MT/VW

New item

Pair of claws for disconnecting suction manifolds in VAG cars

Can be used on turbocharged petrol engines 1.0 - 1.2 - 1.4

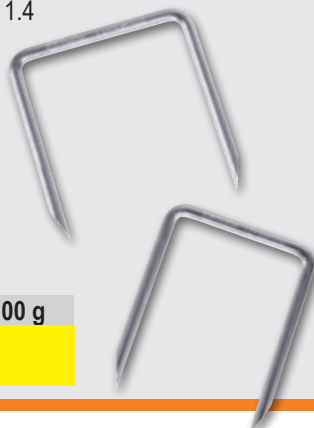

014720500 100 g

989A

Pliers for removing wheel balancing adhesive weights

Nose profile specially designed to remove weights without making contact with rim

No risk of damage

New item



009890011 400 g

1471M/C22

Pneumatic tool for pushing back and rotating right and left disc brake pistons with accessories, in plastic case

- Automatic jack
- Thrust: 150 kg
- Operating pressure 5-8 bar

350x310x85 mm



014710101 3,8 kg

1567

Lever for removing wishbone heads and shock absorbers from pillar

One operator can position lever effortlessly and proceed with disassembly



It is enough to apply a force of 20 Nm

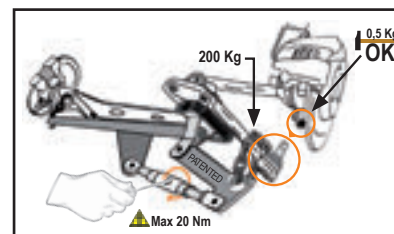
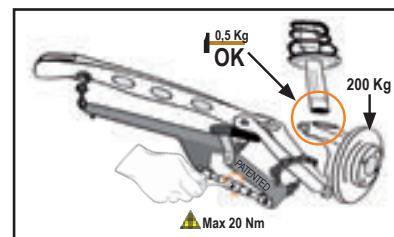

015670001 5,5 kg

1479/B 27

Kit of 27 nylon tools for removing pins and working on plastics and seals

Convenient hanging wallet for viewing all tools



014790407 900 g





3035

Tyre trolley

- For easily transporting tyres up to 980 mm in diameter
- The sturdy frame allows tyres to be handled without bearing the weight physically
- Can be used as a top by locking position horizontally
- 2 castors Ø 260 mm
- 2 castors Ø 125 mm
- Maximum transportable height: 1.60 m
- Maximum carrying capacity: 200 kg
- Forks can be adjusted in 2 positions:
first position: maximum opening 880 mm
second position: maximum opening 980 mm



030350100 30 kg



3036

Wheel handling base Non-marking rubber castors

Max 150 Kg



Ø 630 mm

030360063 4,2 kg

New item



3009

Wheel lifter

- Maximum lifting capacity: 550 kg
- 4 pivoting rollers
- Roller width: 200 mm
- For wheels up to 240 mm in width



030090001 21,8 kg

Ideal for:

- loading damaged cars onto tow trucks
- car repair garages
- moving cars in showrooms

1550U

Pneumatic shock absorber removal tool for cars, SUVs and commercial vehicles

- upper universal hold system
- active safety system on spring
- protective "full body" grille

Supplied with 2 lower forks for diameters 78-205 mm

TECHNICAL DATA

Maximum thrust:

2 tons (10 bars) - 1.6 tons (8 bars) - 1.2 tons (6 bars)

Spring compression stroke: 335 mm



015500010

87,5 kg



1550U/SS187

Left-hand fork for item 1550U

Particularly suitable for left-hand springs, e.g. Nissan Qashqai and Renault Koleos

015500018

4,4 kg



1550U/M

Vice for shock absorber removal tool item 1550U

Allows shock absorber stem to be locked

015500021

4 kg



Maximum thrust 2 tons (10 bar)

1670 mm
610 mm
825 mm



2254F

Car front protector

Allows front part of vehicle to be protected, while leaving openings for headlights and radiator

- Waterproof
- Resistant to oil and grease
- Strap fixing
- Material: 98% polyamide/nylon, 2% polyurethane



022540150

800 g

2254SV

Reusable seat and steering wheel protector

Suits most car seats and steering wheels

- One size fits all
- Reusable and washable
- Made of hard-wearing nylon with stretch strings
- Material: 98% polyamide/nylon, 2% polyurethane



022540100

170 g





1360/KP3 *New item*

Hammers with ball heads and point peins/punches, made of plastic

Kit contents:

- 1 210 g hammer with head Ø 30 mm
- 1 290 g hammer with head Ø 40 mm
- 1 75 g punch with 5 mm pein



013600503 580 g

1361/C12 *New item*

Set of Teflon® rods for body repair shops



275x160x57 mm

013610012 600 g

1365/K13

Oil pressure pump, 10 t, and bodywork accessories kit in handy trolley

Kit contents:

- oil pressure pump and piston
- wing opening pliers
- L-shaped base
- male-to-male coupling for installing accessories



900x420x180 mm

013650013 33 kg

1479ML/S3 *New item*

Kit of 3 multipurpose wrecking bars, made of plastic

Particularly recommended for precision jobs



014790603 15 g

3002

Creepers and seat

- Steel frame
- PVC lining with upholstery
- Easily convertible into a creeper or a seat

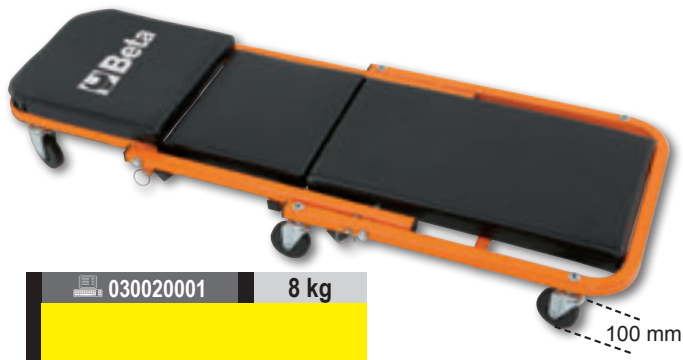

030020001 8 kg

3003

Creepers made of shockproof plastic

- Wheel Ø: 76 mm



030030001 5 kg

2254T

Kneeling pad

Made from non-slip EVA foam



022540047 200 g



2250-0

Heavy duty swivel creeper seat with tray

- Round swivel seat
- Height can be adjusted through a gas piston mechanism (410-530 mm)
- 5 pivoting castors

2 tote/tool trays, one being vertically adjustable

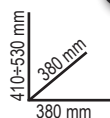
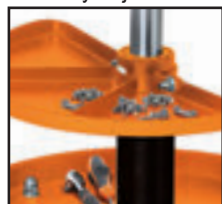

022500011 6 kg

1498PC

Voltage stabilizer, 12-24 V

Protects control units in welding and starting processes

12-24 V



014980801 300 g





3029/2T

Lowered hydraulic jack, 2 t, with 4 wheels

- Quick approach pedal
- Steel frame and nylon wheels
- Minimum height: 75 mm

**Min height: 75 mm
Max height: 500 mm**

New item



Maximum capacity: 2 tons

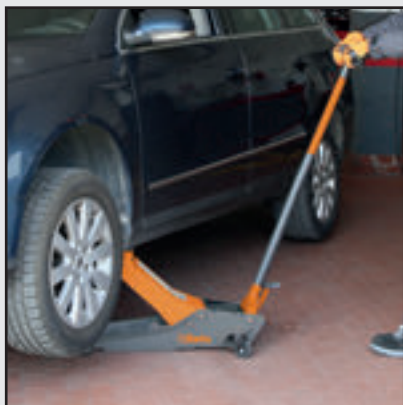

030290020 36 kg

3029L/2T

Long, lowered hydraulic jack, 2 t

- Makes it possible to work on vehicles with a reduced height from the ground and internal lifting point
- Controlled descent speed
 - Quick approach pedal
 - Nylon wheels

**Min height: 75 mm
Max height: 530 mm**

New item

Maximum capacity: 2 tons

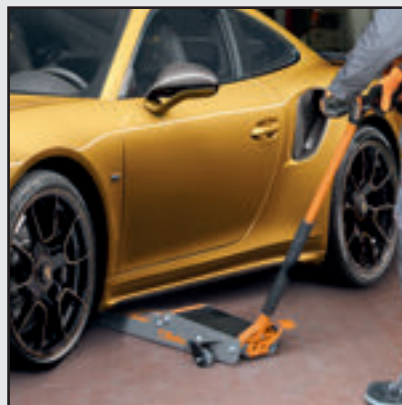

030290120 41 kg

3030/2T

Lowered hydraulic car jack, 2 t with 6 wheels

- Car jack can be easily handled on uneven, irregular floors
- Dual front tilting wheels made of plastic material (PTFE)
- Pedal allows easy approach

**Min height: 85 mm
Max height: 520 mm**

Maximum capacity: 2 tons



030300020 45 kg

3025

Folding hydraulic crane with dual effect pump

Maximum capacity: 1 t

- Folding frame for significantly increased compactness
- 4 loading positions: 450-650-800-1000 kg
- Controlled descent speed



3025/PF

Barrel handling pliers

Maximum capacity:
300 kg



CB52-0

Gearbox/transmission trolley with liquid recovery system

Inclined plane and drain holes allow liquids to be recovered in collection tank

Fitted with:

- 4 swivel castors, including 2 with brakes
- tool drawer
- pull-out liquid collection tank; capacity: 7 l
- 2 shelves



3010T

Jack stands, pair

	Max kg	H min mm	H Max mm		
3010/T2	2000	280	425	030100002	
3010/T3	3000	285	430	030100003	
3010/T6	6000	400	580	030100006	
3010/T10	10000	471	735	030100010	





8143

Hand chain blocks

- Professional model made of first-rate materials
- Automatic brake with double pawl system
- Swivel hook with safety latch

Robur



CE

New item

EN13157

8143 1 t

WLL t	L m
1	3

081430010 12 kg

8143 2 t

WLL t	L m
2	3

081430020 20 kg

8146C

Lever hoist, compact

- Professional model easy to install and use
- Automatic brake with double pawl system for optimized safety
- Roller bearings for increased smoothness and durability
- Swivel hook with safety latch

Robur

Lightweight, portable



CE

New item

EN13157

8146C 0,25 t

WLL t	L m
0,25	1,5

081460002 2,5 kg

8146

Lever hoists

- Professional model easy to install and use
- Automatic brake with double pawl system for optimized safety
- Roller bearings for increased smoothness and durability
- Swivel hook with safety latch

Robur



CE

New item

EN13157

8146 0,75 t

WLL t	L m
0,75	1,5

081460008 7 kg

8146 1,5 t

WLL t	L m
1,5	1,5

081460015 11 kg

MADE IN ITALY

New item

11001

Abrasive **steel cutting** discs with depressed centre
 • S = 3,2 mm



110010128

11011H

Abrasive **steel grinding** discs with depressed centre
 • S = 6,5 mm



110110625

11011H

Abrasive **steel grinding** discs with depressed centre
 • S = 6,5 mm



110110680

11035 1,0

Abrasive **steel and stainless steel cutting** discs, thin, with flat centre
 • Top Line
 • S = 1,0 mm



110350022

11035 1,6

Abrasive **steel and stainless steel cutting** discs, thin, with flat centre
 • Top Line
 • S = 1,6 mm



110350062

11216B40

Flap discs with zirconia abrasive cloth, **fibreglass** backing pad, **single flap** construction
 • Top Line
 • Grain 40



125 mm

112160104

11216B60

Flap discs with zirconia abrasive cloth, **fibreglass** backing pad, **single flap** construction
 • Top Line
 • Grain 60



125 mm

112160106

11218B40

Flap discs with zirconia abrasive cloth, **fibreglass** backing pad, **double flap** construction
 • Top Line
 • Grain 40



125 mm

112180104

11220B40

Flap discs with zirconia abrasive cloth, **fibreglass** backing pad, **single flap** construction
 • Top Line
 • Grain 40



125 mm

112200104

11248B40

Flap discs with **ceramic-coated** abrasive cloth, **fibreglass** backing pad and **single flap** construction
 • Top Line
 • Grain 40



125 mm

112480104



1927XM

Compact reversible impact wrench

- single hammer impulse device
- amazingly compact and powerful
- one-hand reverse button
- three power adjustable screwing positions
- exhaust through handle
- balancing hook

Free speed	rpm	10.000
Impulse device		Single hammer
Max. torque	Nm	770
Bolt capacity	Cl 8.8	M22●34 mm
Bolt capacity	Cl 12.9	M18●27 mm
Air inlet	GAS	1/4"
Operating pressure	bar	6,2
Internal hose size (Ø)	mm	10
Mean air consumption	l/min	122

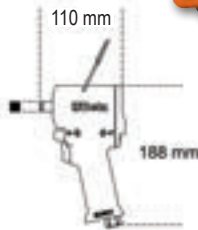

019270030 1,3 kg

1927XM/K5

Assortment of 1 compact reversible impact wrench and 5 impact sockets, in plastic case

720 17-19-21-22-24 mm



307x206x86 mm

019270129 2,8 kg

1927CD

Reversible impact wrench

- Double hammer impulse device
- Lightweight and well-balanced for enhanced ease of use
- High torque
- Reversible lever
- Three power adjustable screwing positions
- Exhaust through handle
- Silenced

Free speed	rpm	7.000
Impulse device		Double hammer
Max. torque	Nm	1020
Bolt capacity	Cl 8.8	M22●34 mm
Bolt capacity	Cl 12.9	M18●27 mm
Air inlet	GAS	1/4"
Operating pressure	bar	6,2
Internal hose size (Ø)	mm	10
Mean air consumption	l/min	130

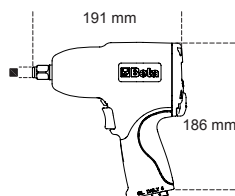

019270007 2,3 kg

1927CD/K3

Assortment of 1 reversible impact wrench and 3 impact sockets

350x305x86 mm



720LC 17-19-21 mm

019270107 4 kg

1927P

Reversible impact wrench

- Double hammer impulse device
- Lightweight and well-balanced for enhanced ease of use
- Reversible lever
- Three power adjustable screwing positions
- Exhaust through handle
- Vibration-damping handle

Free speed	rpm	7.500
Impulse device		Double hammer
Max. torque	Nm	1750
Bolt capacity	Cl 8.8	M24●36 mm
Bolt capacity	Cl 12.9	M20●30 mm
Air inlet	GAS	1/4"
Operating pressure	bar	6,2
Internal hose size (Ø)	mm	10
Mean air consumption	l/min	290

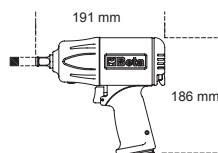

019270008 2 kg

1927P/K3

Reversible impact wrench, supplied with 3 impact sockets

720LC 17-19-21 mm

New item



350x305x86 mm

019270118 3,5 kg



1927B

1/2"

Reversible impact wrench

- "Pin Clutch" impulse device
- Rubber handle
- Reversible lever
- Three power adjustable screwing positions
- Exhaust through handle



Free speed	rpm	7.000
Impulse device		Pin Clutch
Max. torque	Nm	705
Bolt capacity	Cl 8.8	M22●34 mm
Bolt capacity	Cl 12.9	M18●27 mm
Air inlet	GAS	1/4"
Operating pressure	bar	6,2
Internal hose size (Ø)	mm	10
Mean air consumption	l/min	133

019270022 2,1 kg

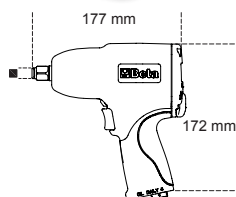

720ME/C8

1/2"

8 impact socket drivers for hexagon screws

○ 5-6-8-10-12-14-17-19 mm



007200525 1,7 kg

270x120x45 mm

1927G

1/2"

Compact reversible impact wrench

- Single hammer impulse device
- Aluminium motor housing with composite handle
- One-handed reverse control
- Three power adjustable screwing positions
- Exhaust through handle
- Head motor with direct rotation transmission to output drive, resulting in improved body balancing and increased handiness

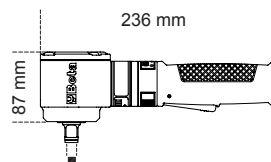

Free speed	rpm	8.500
Impulse device		Single hammer
Max. torque	Nm	325
Bolt capacity	Cl 8.8	M16●24 mm
Bolt capacity	Cl 12.9	M14●21 mm
Air inlet	GAS	1/4"
Operating pressure	bar	6,2
Internal hose size (Ø)	mm	10
Mean air consumption	l/min	113

019270050 1,2 kg



720LC/C3

1/2"

3 impact sockets for wheel nuts, with polymeric inserts, in plastic case

○ 17-19-21 mm



007200653 800 g

148x132x44 mm

720/C24

1/2"

Set of 24 impact sockets, 1/2" female drive, in metal case

Quantity/Description	Beta N.
15 10-12-13-14-15-16-17-18 19-21-22-24-27-30-32 mm	720
6 13-17-19-21-22-24 mm	720L
3 17-19-21 mm	720LC

New item



007200904 1,7 kg



1928XM

New item

3/4"

Compact reversible impact wrench

- double hammer impulse device
- amazingly compact and powerful
- one-hand reverse button
- three power adjustable screwing positions
- exhaust through handle



1.600 Nm

Free speed	rpm	4.800
Impulse device		Double hammer
Max. torque	Nm	1600
Bolt capacity	Cl 8.8	M27●41 mm
Bolt capacity	Cl 12.9	M24●36 mm
Air inlet	GAS	3/8"
Operating pressure	bar	6,2
Internal hose size (Ø)	mm	10
Mean air consumption	l/min	175



Ultra compact and powerful

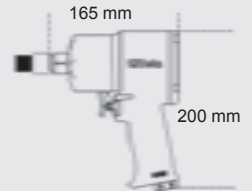

019280030

2,9 kg



1928DA

3/4"

Reversible impact wrench

- Double hammer impulse device
- Sturdy and compact; high torque
- Reversible lever
- Three power adjustable positions
- Exhaust through handle
- Slip-proof ergonomic handle



Free speed	rpm	5.000
Impulse device		Double hammer
Max. torque	Nm	1.695
Bolt capacity	Cl 8.8	M30●46 mm
Bolt capacity	Cl 12.9	M27●41 mm
Air inlet	GAS	3/8"
Operating pressure	bar	6,2
Internal hose size (Ø)	mm	10
Mean air consumption	l/min	210

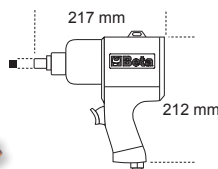

019280022

4,3 kg



1928CD

3/4"

Reversible impact wrench

- Double hammer impulse device
- High weight/power ratio
- Reversible lever
- Three power adjustable screwing positions
- Exhaust through handle
- Silenced



Free speed	rpm	4.500
Impulse device		Double hammer
Max. torque	Nm	1.800
Bolt capacity	Cl 8.8	M27●41 mm
Bolt capacity	Cl 12.9	M24●36 mm
Air inlet	GAS	3/8"
Operating pressure	bar	6,2
Internal hose size (Ø)	mm	10
Mean air consumption	l/min	215

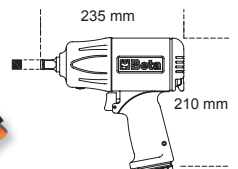

019280007

3,5 kg



1930PA

Reversible impact wrench

- Double hammer impulse device
- Auxiliary handle
- Reversible lever
- Three power adjustable screwing/unscrewing positions
- Exhaust through handle



Free speed	rpm	3.500
Impulse device		Double hammer
Max. torque	Nm	2445
Bolt capacity	CI 8.8	M36 ● 55mm
Bolt capacity	CI 12.9	M30 ● 46mm
Air inlet	GAS	1/2"
Operating pressure	bar	6,2
Internal hose size (Ø)	mm	13
Mean air consumption	l/min	350

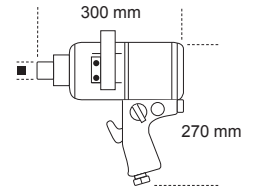

019300032

9,6 kg



1930LH

Reversible impact wrench

- Double hammer impulse device
- 210 mm (8.3") long anvil
- New 70-degree angled handle design to relieve stress and fatigue on the operator's wrists
- Auxiliary side handle
- 3 power adjustable screwing/unscrewing positions
- Lower exhaust



Excellent weight/power ratio



Free speed	rpm	6.000
Impulse device		Double hammer
Max. torque	Nm	2.441
Bolt capacity	CI 8.8	M36 ● 55 mm
Bolt capacity	CI 12.9	M30 ● 46 mm
Air inlet	GAS	1/2"
Operating pressure	bar	6,2
Internal hose size (Ø)	mm	13
Mean air consumption	l/min	280

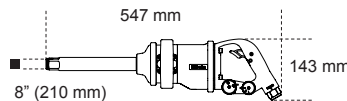

019300030

7,1 kg



1930LA

Reversible impact wrench

- Double hammer impulse device
- 8" long anvil
- Auxiliary handle
- Reversible lever
- Three power adjustable screwing positions
- Lower exhaust



Free speed	rpm	4.000
Impulse device		Double hammer
Max. torque	Nm	2.445
Bolt capacity	CI 8.8	M36 ● 55 mm
Bolt capacity	CI 12.9	M30 ● 46 mm
Air inlet	GAS	1/2"
Operating pressure	bar	6,2
Internal hose size (Ø)	mm	13
Mean air consumption	l/min	460

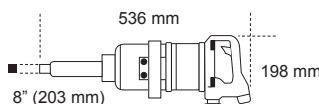

019300037

10,6 kg



1937

Roto-orbital palm sander, lubrication free, made from composite material

- No lubrication required
- Extremely compact and easy to handle
- 6-hole Velcro pad
- Continuous motor speed adjustment
- Nonslip, soft material handle
- Designed for connection to suction systems with swivel fittings
- Revolving exhaust



Orbit diameter
2,5 mm
5,0 mm

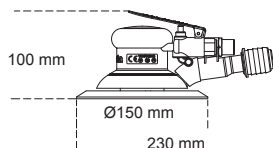

Lubrication free

Free speed	rpm	12.000
Power	kW	0,18
Pad size	mm	150
Spindle thread		5/16"-24
Air inlet	GAS	1/4"
Operating pressure	bar	6,2
Internal hose size (Ø)	mm	10
Mean air consumption	l/min	170

	Ø Orbit mm	g	
1937 2,5	2,5	860	019370000
1937	5,0	860	019370001

Reversible air impact ratchets

- "Double rocking dog" impulse device
- Easy tightening: The impact mechanism system eliminates wrist twisting at end of screwing and shortens operating time
- Compact and powerful: maximum torque is significantly higher than maximum torque as achieved with a conventional ratchet
- Ergonomic rubber handle



68 Nm

164 mm

Free speed	rpm	700
Power	kW	68
Pad size	mm	M10●16 mm
Spindle thread		M8●13 mm
Air inlet	GAS	1/2"
Operating pressure	bar	6,2
Internal hose size (Ø)	mm	10
Mean air consumption	l/min	88

1922P1 **14"**
019220006 0,6 kg

1922P2 **3/8"**
019220010 0,6 kg

High torque without affecting wrist

136 Nm



292 mm

1922P3 **12"**
019220013 1,5 kg



Free speed	rpm	600
Power	kW	136
Pad size	mm	M12●18 mm
Spindle thread		M10●16 mm
Air inlet	GAS	1/2"
Operating pressure	bar	6,2
Internal hose size (Ø)	mm	10
Mean air consumption	l/min	113

1933IH

High-power die grinder

- Collect chuck, Ø 3 mm and 6 mm

New item

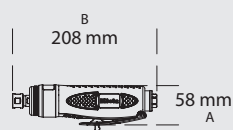

Free speed	rpm	20.000
Chuck capacity	mm	3-6
Power	kW	0,75
Air inlet	GAS	1/4"
Working pressure	bar	6,2
Internal hose size (Ø)	mm	10
Mean air consumption	l/min	370

019330006

800 g

1933ILH

High-power long spindle die grinder

- Collect chuck, Ø 3 mm and 6 mm

New item

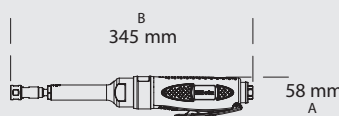

Free speed	rpm	20.000
Chuck capacity	mm	3-6
Power	kW	0,75
Air inlet	GAS	1/4"
Working pressure	bar	6,2
Internal hose size (Ø)	mm	10
Mean air consumption	l/min	370

019330011

1,2 kg

1933AN90-H

High-power angle grinder

- Collect chuck, Ø 3 mm and 6 mm

New item

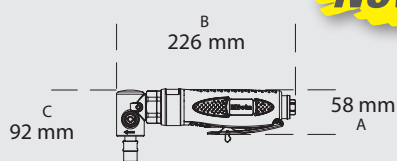

Free speed	rpm	15.000
Chuck capacity	mm	3-6
Power	kW	0,75
Air inlet	GAS	1/4"
Working pressure	bar	6,2
Internal hose size (Ø)	mm	10
Mean air consumption	l/min	370

019330021

1,1 kg

1936/5A

Angle grinder

- Extremely compact and handy
- Air governor for automatically controlling top speed
- Right-hand/left-hand auxiliary handle
- Spindle lock button
- Accessory for quickly changing discs
- Safety cap can be quickly adjusted in nine different positions through quick release
- Rear exhaust



Ø 125 mm

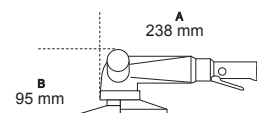

Free speed	rpm	10.000
Grinding disc size	mm	125
Power	kW	0,66
Spindle thread	M	14
Air inlet	GAS	1/4"
Working pressure	bar	6,2
Ø internal hose size	mm	10
Mean air consumption	l/min	390

019360025

1,9 kg



1945C

Stapler, nailer, combo tool

- Rubber coated handle
- Lightweight aluminium body
- Air exhaust can be rotated 360 degrees
- Safety device on tip
- Jam clearing mechanism
- Fields of use: building wood frames and packing cases, applying coatings and insulating materials, fixing skirting boards and glazing frames



Magazine capacity	pcs	100
Air inlet	GAS	1/4"
Working pressure	bar	5-8
Internal hose size (Ø)	mm	8
Air consumption (7 bar)	l/cycle	1,12

019450200 1,1 kg

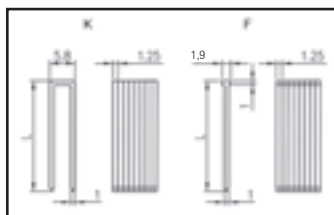

1945C/G

1945C/GP

1945C/G... *New item*

Staples

Type 90, section 1.25x1.0 mm (18-Gauge), width 5.8 mm, for item 1945C

L mm	
16	019450216
19	019450219
22	019450222
25	019450225
28	019450228
32	019450232
35	019450235
38	019450238
40	019450240

1945C/GP... *New item*

Nails

Type B12, section 1.25x1.0 mm (18-Gauge), 1.9 mm-head, for item 1945C

L mm	
15	019450255
16	019450256
20	019450260
25	019450265
30	019450270
32	019450272
35	019450275
38	019450278
40	019450280
45	019450285
50	019450290

1945S

Stapler

- Rubber coated handle
- Lightweight aluminium body
- Air exhaust can be rotated 360 degrees
- Safety device on trigger
- Fields of use: footwear industry, building and finishing furniture, frames, building doors and windows, fair installations, sewing bags



Magazine capacity	pcs	157
Air inlet	GAS	1/4"
Working pressure	bar	4,2-7
Internal hose size (Ø)	mm	8
Air consumption (7 bar)	l/cycle	0,34

019450000 870 g

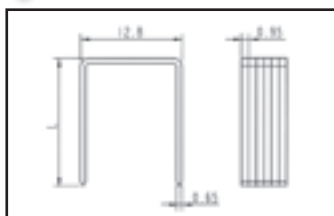

1945S/G

1945S/G... *New item*

Staples

Type 80, section 0.95x0.65 mm (21-Gauge), width 12.8 mm, for item 1945S

L mm	
4	019450004
6	019450006
8	019450008
10	019450010
12	019450012
14	019450014
16	019450016

1945P

Headless pinner

- Rubber coated handle
- Lightweight aluminium body
- Safety device on trigger
- Fields of use: concealing fixings, finishing furniture, making frames, fixing staff beads



Magazine capacity	pcs	145
Air inlet	GAS	1/4"
Working pressure	bar	4-7
Internal hose size (Ø)	mm	8
Air consumption (7 bar)	l/cycle	0,27

019450100 870 g

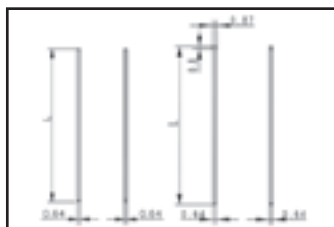

1945P/S

1945P/S... *New item*

Pins

Type B6, Ø 0.64 mm (23-Gauge), for item 1945P

L mm	
12	019450112
15	019450115
18	019450118
20	019450120
21	019450121
22	019450122
25	019450125
30	019450130
35	019450135

1951A

New item

Suction cleaning gun

- For cleaning car upholstery, carpeting, seats and boots
- For use with suitable detergents
- 1L tank
- Fitted with a tap for dispensing liquid from tank
- Complete with corrugated tube, 1.8 m long



Tank capacity	liters	1
Air inlet	GAS	1/4"
Working pressure	bar	6,2
Internal hose size (Ø)	mm	8
Air consumption	l/min	120

019510101 800 g

1942A

Air saw

- Powerful and handy
- Designed for cutting bodies, exhaust pipes and silencers, aluminium and plastic
- Complete with rubber handle, PVC exhaust pipe and air-feeding hose
- Rear exhaust

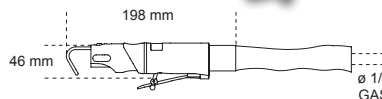
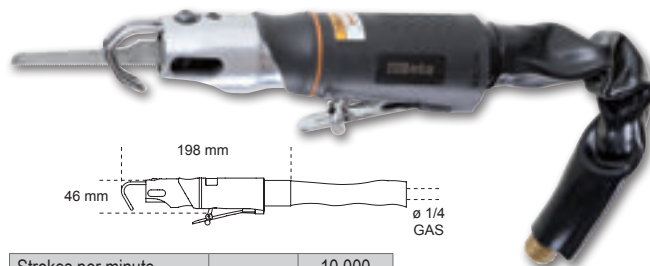

Strokes per minute		10.000
Stroke length	mm	10
Air inlet	GAS	1/4"
Operating pressure	bar	6,2
Internal hose size (Ø)	mm	8
Mean air consumption	l/min	75



019420000 550 g

1946C4,8

Automatic air suction riveter

- Professional air riveter for use with 2.4 - 3.2 - 4.0 - 4.8 mm long steel, stainless steel, aluminium and copper rivets
- Pointed cone-shaped spout
- Powerful and handy, with handle made of composite material
- Complete with safety nail container and oil gun



Material/Riveter	2,4	3,2	4	4,8
copper	✓	✓	✓	✓
aluminium	✓	✓	✓	✓
steel	✓	✓	✓	✓
stainless steel	✓	✓	✓	✓

Traction power	N	8.900
Stroke length	mm	15
Maximum rivet capacity	Ø stainless steel	4,8 mm
Air inlet	GAS	1/4"
Working pressure	bar	6,2
Internal hose size (Ø)	mm	10
Air consumption	l/cycle	2,6

019460006 1,5 kg

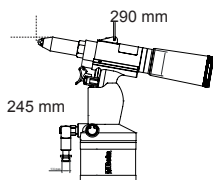

Automatic hose reels

- Shock-proof plastic body for compressed air or cold water
- Metal clamp, revolving
- Device for automatically fixing hose at desired length

1901BM/8 1901T/10

Air inlet	GAS	1/4"	3/8"
Hose length	m	9+1	15+1
Max. operating pressure	bar	12	15
Internal hose size Ø	mm	8	10
Tube material		Polyurethane	Polyurethane

1901BM/8

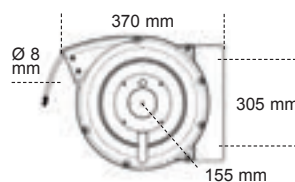

019010111 3,5 kg



1901T/10

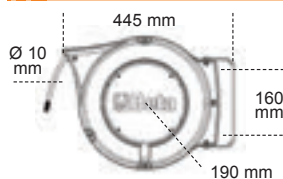

019010210 6,5 kg





1952

New item

Professional paint spray gun

- Die-cast aluminium body plated with black chemical nickel
- Nylon cup with drip-catching device, 3/8M BSP thread
- Body thread: 1/4" BSP cylindrical gas thread
- Pressure and airflow regulator
- Jet regulator from round to fan spray pattern
- Paint quantity regulator
- Supplied with service spanner for maintenance operations



jet Ø		
1952 1,2	019520012	
1952 1,5	019520015	
1952 1,8	019520018	
1952 2,0	019520020	

1949DGT

Digital tyre inflator

- Operating pressure: 0÷11 bar (2.0÷160 psi)
- 4 units of measurement: psi/bar/kgcm²/kpa
- Backlit LCD display
- Reset feature
- Self-power off after 3 min.
- Pressure release button
- Resolution: 0.05 bars
- ABS housing, protective rubber shell on gauge, shockproof, nonslip handle grip
- Power supply: 2 AAA size 1.5V batteries
- Compatible with coupling 1916G 1/4"



019490020 500 g

1949U5

New item

Progressive blow gun with 5 nozzles

- Hard-wearing, shockproof composite material body
- 3 steel nozzles, 100/160/320 mm, scratchproof, protective rubber tips
- 1 "Turbo" nozzle made of fibreglass-reinforced nylon with safety tip
- 1 revolving nozzle, 100 mm, made of fibreglass-reinforced nylon
- With quick fixing system



019490030 230 g

How many steps do you walk in a day?
And in a year?

New item

“0-Gravity” range

100 grams less for each step walked mean saving approximately
1000 kilos a day and over **200 tons a year!**

¹ compared to the average weight of a shoe of the same category, size 42

- EVA outsole with durable nitrile rubber tread
- Stretch slip-on collar
- Heel stability support

**WALK
LIGHTER!**

420 g

(approximate weight, size 42)

EU	UK	
38	5	073530038
39	6	073530039
40	6,5	073530040
41	7	073530041
42	8	073530042
43	9	073530043
44	10	073530044
45	10,5	073530045
46	11	073530046
47	12	073530047
48	13	073530048

7353Y

Mesh fabric shoe, highly breathable, with TPU inserts
High-visibility reflective mesh upper

- Carbon fibre toe cap
- Composite fibre penetration-proof insole



**EN ISO
20345
2011**

S1P HRO SRC

"0-Gravity" range



7352A

New item

Mesh fabric shoe,
highly breathable,
with TPU inserts

- Composite toe cap
- Composite fibre penetration-proof insole

EU	UK	Product Code
38	5	073520038
39	6	073520039
40	6,5	073520040
41	7	073520041
42	8	073520042
43	9	073520043
44	10	073520044
45	10,5	073520045
46	11	073520046
47	12	073520047
48	13	073520048

450 g



EN ISO
20345
2011

S1P HRO SRC

7352B

New item

Mesh fabric shoe,
highly breathable,
with TPU inserts

- Composite toe cap
- Composite fibre penetration-proof insole

EU	UK	Product Code
38	5	073520138
39	6	073520139
40	6,5	073520140
41	7	073520141
42	8	073520142
43	9	073520143
44	10	073520144
45	10,5	073520145
46	11	073520146
47	12	073520147
48	13	073520148

450 g



EN ISO
20345
2011

S1P HRO SRC

7354N

New item

Mesh fabric shoe,
waterproof,
with TPU inserts

- Composite toe cap
- Composite fibre penetration-proof insole

EU	UK	Product Code
38	5	073540038
39	6	073540039
40	6,5	073540040
41	7	073540041
42	8	073540042
43	9	073540043
44	10	073540044
45	10,5	073540045
46	11	073540046
47	12	073540047
48	13	073540048

460 g



EN ISO
20345
2011

S3 HRO SRC

7355V

New item

Mesh fabric ankle shoe,
waterproof,
with TPU inserts

- Composite toe cap
- Composite fibre penetration-proof insole

EU	UK	Product Code
38	5	073550038
39	6	073550039
40	6,5	073550040
41	7	073550041
42	8	073550042
43	9	073550043
44	10	073550044
45	10,5	073550045
46	11	073550046
47	12	073550047
48	13	073550048

465 g



EN ISO
20345
2011

S3 HRO SRC

“FIT PRO” line

7340B

Mesh fabric shoe, highly breathable, with high-frequency PU inserts and protective toe cap reinforcement made of crust suede

- Aluminium toe cap
- Composite fibre penetration-proof insole
- FixLock closing makes it easier to put and remove the shoe (traditional laces included)

EU	UK	Product Code
36	3,5	073400236
37	4,5	073400237
38	5	073400238
39	6	073400239
40	6,5	073400240
41	7	073400241
42	8	073400242
43	9	073400243
44	10	073400244
45	10,5	073400245
46	11	073400246
47	12	073400247



FIT PRO NET



EN ISO 20345 2011

S1P SRC

7340R

Mesh fabric shoe, highly breathable, with high-frequency PU inserts and protective toe cap reinforcement made of crust suede

- Aluminium toe cap
- Composite fibre penetration-proof insole
- FixLock closing makes it easier to put and remove the shoe (traditional laces included)

EU	UK	Product Code
36	3,5	073400436
37	4,5	073400437
38	5	073400438
39	6	073400439
40	6,5	073400440
41	7	073400441
42	8	073400442
43	9	073400443
44	10	073400444
45	10,5	073400445
46	11	073400446
47	12	073400447



FIT PRO NET



EN ISO 20345 2011

S1P SRC

7341N

Microsuede shoe, waterproof, with high-frequency PU inserts and protective toe cap reinforcement made of crust suede

- Aluminium toe cap
- Composite fibre penetration-proof insole
- FixLock closing makes it easier to put and remove the shoe (traditional laces included)

EU	UK	Product Code
36	3,5	073410236
37	4,5	073410237
38	5	073410238
39	6	073410239
40	6,5	073410240
41	7	073410241
42	8	073410242
43	9	073410243
44	10	073410244
45	10,5	073410245
46	11	073410246
47	12	073410247



FIT PRO



EN ISO 20345 2011

S3 SRC

7398U

Anatomically shaped underfoot covers made of TPR GEL with high cushioning effect, plantar arch support and heel pad

Size Range	Product Code
36-40	073980058
41-46	073980063





"ACTIVE" line

7314AF

Suede shoe with nylon mesh and carbon inserts

- Composite toe cap
- Composite fibre penetration proof insole

EU	UK	鞋
35	2,5	073140235
36	3,5	073140236
37	4,5	073140237
38	5	073140238
39	6	073140239
40	6,5	073140240
41	7	073140241
42	8	073140242
43	9	073140243
44	10	073140244
45	10,5	073140245
46	11	073140246
47	12	073140247
48	13	073140248



EN ISO 20345 2011

S1P SRC

7314AB

Suede shoe with nylon mesh and carbon inserts

- Composite toe cap
- Composite fibre penetration proof insole

EU	UK	鞋
35	2,5	073140335
36	3,5	073140336
37	4,5	073140337
38	5	073140338
39	6	073140339
40	6,5	073140340
41	7	073140341
42	8	073140342
43	9	073140343
44	10	073140344
45	10,5	073140345
46	11	073140346
47	12	073140347
48	13	073140348



EN ISO 20345 2011

S1P SRC

7315AN

Suede and microfibre shoe, water-repellent, with carbon inserts

- Composite toe cap
- Composite fibre penetration proof insole

EU	UK	鞋
35	2,5	073150535
36	3,5	073150536
37	4,5	073150537
38	5	073150538
39	6	073150539
40	6,5	073150540
41	7	073150541
42	8	073150542
43	9	073150543
44	10	073150544
45	10,5	073150545
46	11	073150546
47	12	073150547
48	13	073150548



EN ISO 20345 2011

S3 SRC

7318AN

Suede and microfibre ankle shoe, water-repellent, with carbon inserts

- Composite toe cap
- Composite fibre penetration proof insole

EU	UK	鞋
35	2,5	073180535
36	3,5	073180536
37	4,5	073180537
38	5	073180538
39	6	073180539
40	6,5	073180540
41	7	073180541
42	8	073180542
43	9	073180543
44	10	073180544
45	10,5	073180545
46	11	073180546
47	12	073180547
48	13	073180548



EN ISO 20345 2011

S3 SRC

“FLEX” line

Extremely flexible and lightweight (approximate weight, size 42:  490 g)



7212FG

Suede shoe, perforated, with anti-abrasion insert in toe cap area

- Composite toe cap
- Composite fibre penetration-proof insole

EU	UK	
35	2,5	072120035
36	3,5	072120036
37	4,5	072120037
38	5	072120038
39	6	072120039
40	6,5	072120040
41	7	072120041
42	8	072120042
43	9	072120043
44	10	072120044
45	10,5	072120045
46	11	072120046
47	12	072120047
48	13	072120048



EN ISO 20345 2011

S1P SRC

7213FG

Suede shoe with highly breathable mesh inserts

- Composite toe cap
- Composite fibre penetration-proof insole

EU	UK	
35	2,5	072130035
36	3,5	072130036
37	4,5	072130037
38	5	072130038
39	6	072130039
40	6,5	072130040
41	7	072130041
42	8	072130042
43	9	072130043
44	10	072130044
45	10,5	072130045
46	11	072130046
47	12	072130047
48	13	072130048



EN ISO 20345 2011

S1P SRC

7214FN

Action nubuck shoe, waterproof, with anti-abrasion insert in toe cap area

- Composite toe cap
- Composite fibre penetration-proof insole

EU	UK	
35	2,5	072140035
36	3,5	072140036
37	4,5	072140037
38	5	072140038
39	6	072140039
40	6,5	072140040
41	7	072140041
42	8	072140042
43	9	072140043
44	10	072140044
45	10,5	072140045
46	11	072140046
47	12	072140047
48	13	072140048



EN ISO 20345 2011

S3 SRC

7218FN

Action nubuck ankle shoe, water-repellent, with anti-abrasion insert in toe cap area and quick opening system

- Composite toe cap
- Composite fibre penetration-proof insole

EU	UK	
35	2,5	072180035
36	3,5	072180036
37	4,5	072180037
38	5	072180038
39	6	072180039
40	6,5	072180040
41	7	072180041
42	8	072180042
43	9	072180043
44	10	072180044
45	10,5	072180045
46	11	072180046
47	12	072180047
48	13	072180048



QUICK OPENING SYSTEM

EN ISO 20345 2011

S3 RS SRC



7214LN

Women's suede shoe, waterproof, with anti-abrasion insert in toe cap area

- Composite toe cap
- Composite fibre penetration proof insole

EU	UK	Product Code
34	2,5	072140134
35	3,5	072140135
36	4,5	072140136
37	5	072140137
38	6	072140138
39	6,5	072140139
40	7	072140140
41	8	072140141
42	9	072140142



EN ISO 20345 2011
S3 SRC

7293HN

Nubuck shoe, waterproof, with SUPPORT SYSTEM for lateral ankle support

- Steel toe cap
- Composite fibre penetration proof insole

EU	UK	Product Code
39	6	072930839
40	6,5	072930840
41	7	072930841
42	8	072930842
43	9	072930843
44	10	072930844
45	10,5	072930845
46	11	072930846
47	12	072930847



EN ISO 20345 2011

S3 HRO HI SRC

7294HN

Nubuck ankle shoe, waterproof, with SUPPORT SYSTEM for lateral ankle support and quick opening system

- Steel toe cap
- Composite fibre penetration proof insole

EU	UK	Product Code
39	6	072940839
40	6,5	072940840
41	7	072940841
42	8	072940842
43	9	072940843
44	10	072940844
45	10,5	072940845
46	11	072940846
47	12	072940847

QUICK OPENING SYSTEM



EN ISO 20345 2011

S3 HRO HI SRC

7236BK

Action Nubuck ankle shoe, waterproof, with quick opening system and reinforcement polyurethane toe cap cover

- Steel toe cap
- Composite fibre penetration proof insole

EU	UK	Product Code
35	2,5	072360335
36	3,5	072360336
37	4,5	072360337
38	5	072360338
39	6	072360339
40	6,5	072360340
41	7	072360341
42	8	072360342
43	9	072360343
44	10	072360344
45	10,5	072360345
46	11	072360346
47	12	072360347
48	13	072360348



EN ISO 20345 2011

S3 RS SRC

HEAVYDUTY

THE BEST PERFORMANCE 100% MADE IN ITALY



- **Upper:** Greased full-grain leather, waterproof, with reinforcement polyurethane toe cap cover and anti-abrasion insert on heel area
- **Toe Cap:** Fibreglass, 200 joules
- **Penetration-proof insole:** Composite fibre, ceramic treatment.
- **WIDE BODY**



- VIBRAM® "Ranger" rubber tread, heat resistant outsole (HRO), designed to provide unparalleled performance
- Polyurethane foam midsole of low specific weight
- Polyurethane reinforced cover



- Black fabric bound to PE and EVA, a material which does not get deformed and regains its initial shape when the foot is taken out of the shoe. Perforated sole to offer better breathability and ABS heel insert varying in density for improved shock absorption with the ground

7293HM

EU	UK	Product Code
39	6	072930639
40	6,5	072930640
41	7	072930641
42	8	072930642
43	9	072930643
44	10	072930644
45	10,5	072930645
46	11	072930646
47	12	072930647
48	13	072930648



EN ISO 20345 2011

S3 HRO HI SRC

7294HM

EU	UK	Product Code
39	6	072940639
40	6,5	072940640
41	7	072940641
42	8	072940642
43	9	072940643
44	10	072940644
45	10,5	072940645
46	11	072940646
47	12	072940647
48	13	072940648



EN ISO 20345 2011

S3 HRO HI SRC

7290NA

Full-grain leather, shoe, waterproof, with reinforcement polyurethane toe cap cover and PUT/PTU VIBRAM® outsole.

- Composite toe cap
- Composite fibre penetration proof insole

EU	UK	Product Code
36	3,5	072900336
37	4,5	072900337
38	5	072900338
39	6	072900339
40	6,5	072900340
41	7	072900341
42	8	072900342
43	9	072900343
44	10	072900344
45	10,5	072900345
46	11	072900346
47	12	072900347
48	13	072900348



EN ISO 20345 2011

S3 SRC ESD

7291NA

Full-grain leather ankle shoe, waterproof, with reinforcement polyurethane toe cap cover and PU/PTU VIBRAM® outsole.

- Composite toe cap
- Composite fibre penetration proof insole

EU	UK	Product Code
36	3,5	072910336
37	4,5	072910337
38	5	072910338
39	6	072910339
40	6,5	072910340
41	7	072910341
42	8	072910342
43	9	072910343
44	10	072910344
45	10,5	072910345
46	11	072910346
47	12	072910347
48	13	072910348



EN ISO 20345 2011

S3 SRC ESD





7200BKK

Full-grain leather shoe, waterproof

- Composite toe cap
- Composite fibre penetration proof insole

EU	UK	Product Code
35	2,5	072000235
36	3,5	072000236
37	4,5	072000237
38	5	072000238
39	6	072000239
40	6,5	072000240
41	7	072000241
42	8	072000242
43	9	072000243
44	10	072000244
45	10,5	072000245
46	11	072000246
47	12	072000247
48	13	072000248



EN ISO 20345 2011

S3 SRC

7201BKK

Full-grain leather ankle shoe, waterproof

- Composite toe cap
- Composite fibre penetration proof insole

EU	UK	Product Code
35	2,5	072010435
36	3,5	072010436
37	4,5	072010437
38	5	072010438
39	6	072010439
40	6,5	072010440
41	7	072010441
42	8	072010442
43	9	072010443
44	10	072010444
45	10,5	072010445
46	11	072010446
47	12	072010447
48	13	072010448



EN ISO 20345 2011

S3 SRC



7210BKK

Soft suede shoe, perforated

- Composite toe cap
- Composite fibre penetration proof insole



EN ISO 20345 2011

S1P SRC

EU	UK	Product Code
35	2,5	072100335
36	3,5	072100336
37	4,5	072100337
38	5	072100338
39	6	072100339
40	6,5	072100340
41	7	072100341
42	8	072100342
43	9	072100343
44	10	072100344
45	10,5	072100345
46	11	072100346
47	12	072100347
48	13	072100348



7223PEK

Suede shoe with highly breathable mesh inserts and anti-abrasion reinforcement in toe cap area

- Composite toe cap
- Composite fibre penetration proof insole

EU	UK	Product Code
35	2,5	072230135
36	3,5	072230136
37	4,5	072230137
38	5	072230138
39	6	072230139
40	6,5	072230140
41	7	072230141
42	8	072230142
43	9	072230143
44	10	072230144
45	10,5	072230145
46	11	072230146
47	12	072230147
48	13	072230148



EN ISO 20345 2011

S1P SRC

7224PEK

Suede shoe, perforated, with anti-abrasion reinforcement in toe cap area

- Composite toe cap
- Composite fibre penetration proof insole

EU	UK	Product Code
35	2,5	072240235
36	3,5	072240236
37	4,5	072240237
38	5	072240238
39	6	072240239
40	6,5	072240240
41	7	072240241
42	8	072240242
43	9	072240243
44	10	072240244
45	10,5	072240245
46	11	072240246
47	12	072240247
48	13	072240248



EN ISO 20345 2011

S1P SRC



“BASIC” line

With composite fibre penetration-proof insoles:
INCREASED FLEXIBILITY = INCREASED COMFORT

7241CK

Leather shoe,
water-repellent

- Steel toe cap
- Composite fibre penetration proof insole

EU	UK	Image
35	2,5	072411535
36	3,5	072411536
37	4,5	072411537
38	5	072411538
39	6	072411539
40	6,5	072411540
41	7	072411541
42	8	072411542
43	9	072411543
44	10	072411544
45	10,5	072411545
46	11	072411546
47	12	072411547
48	13	072411548



EN ISO
20345
2011

S3 SRC

7243CK

Leather ankle shoe,
water-repellent,
with quick opening system

- Steel toe cap
- Composite fibre penetration proof insole

EU	UK	Image
35	2,5	072431335
36	3,5	072431336
37	4,5	072431337
38	5	072431338
39	6	072431339
40	6,5	072431340
41	7	072431341
42	8	072431342
43	9	072431343
44	10	072431344
45	10,5	072431345
46	11	072431346
47	12	072431347
48	13	072431348



EN ISO
20345
2011

S3 RS SRC

QUICK OPENING
SYSTEM

7245BK

Lace-up leather ankle shoe,
“welder style”, water-repellent,
with quick opening system
and front protection
with strap closure

- Steel toe cap
- Composite fibre penetration proof insole

EU	UK	Image
35	2,5	072451235
36	3,5	072451236
37	4,5	072451237
38	5	072451238
39	6	072451239
40	6,5	072451240
41	7	072451241
42	8	072451242
43	9	072451243
44	10	072451244
45	10,5	072451245
46	11	072451246
47	12	072451247
48	13	072451248



EN ISO
20345
2011

S3 RS SRC

QUICK OPENING
SYSTEM

7246BK

Suede shoe, perforated

- Steel toe cap
- Composite fibre penetration proof insole

EU	UK	Image
35	2,5	072461235
36	3,5	072461236
37	4,5	072461237
38	5	072461238
39	6	072461239
40	6,5	072461240
41	7	072461241
42	8	072461242
43	9	072461243
44	10	072461244
45	10,5	072461245
46	11	072461246
47	12	072461247
48	13	072461248



EN ISO
20345
2011

S1P SRC



"CASUAL" Work trousers

7810

New item

"Work trekking" trousers, multipocket style

- 90% nylon, 10% stretch fabric, 265 g
- Stretch waistband
- Bi-stretchable fabric for improved comfort
- Stretch leg bottom with vertical zip closure



Heavy

S	078100101
M	078100102
L	078100103
XL	078100104
XXL	078100105

7811

SLIM FIT

"Work trekking" trousers

- 90% nylon, 10% stretch fabric, 265 g
- Stretch waistband
- Bi-stretchable fabric for improved comfort
- Stretch leg bottom with vertical zip closure



Medium

S	078110001
M	078110002
L	078110003
XL	078110004
XXL	078110005

7812

New item

"Work trekking" trousers

- 95% nylon, 5% stretch fabric, 140 g
- Ergonomic fit for ease of movement
- Bi-stretchable fabric for improved comfort
- Reinforced inserts on knees, crotch and leg bottom



Light

S	078120001
M	078120002
L	078120003
XL	078120004
XXL	078120005



HEAVY TREKKING PANTS

SLIM FIT

SIDE POCKETS WITH ZIP CLOSURE ON BOTH LEGS



REINFORCED INSERTS ON KNEES, CROTCH AND LEG BOTTOM

STRETCH LEG BOTTOM WITH VERTICAL ZIP CLOSURE

"LIGHT" Work trousers

7840BL

Work trousers

- T/C twill, 65% polyester, 35% cotton, 245 g
- Hammer loop
- Triple stitching in points more subject to wear
- Metal zip closure
- Ruler pocket with pen or small tool inserts



XS	078400100
S	078400101
M	078400102
L	078400103
XL	078400104
XXL	078400105
XXXL	078400106
XXXXL	078400107

7860E

Work trousers

- T/C twill, 65% polyester, 35% cotton, 180 g
- Hammer loop
- Triple stitching in points more subject to wear
- Metal zip closure
- Ruler pocket with pen or small tool inserts
- Knee pad pockets



XS	078600900
S	078600901
M	078600902
L	078600903
XL	078600904
XXL	078600905
XXXL	078600906
XXXXL	078600907

7870E

Work trousers, lightweight

- T/C twill, 65% polyester, 35% cotton, 180 g
- Hammer loop
- Triple stitching in points more subject to wear
- Metal zip closure
- Ruler pocket with pen or small tool inserts
- Knee pad pockets



XS	078700900
S	078700901
M	078700902
L	078700903
XL	078700904
XXL	078700905
XXXL	078700906
XXXXL	078700907

7830ST

Stretch work trousers

- T/C twill, 63% polyester, 34% cotton, 3% stretch fabric, 250 g
- Tearproof crotch
- Stretch waistband on sides
- Ruler pocket and hammer loop

SLIM FIT



XS	078300000
S	078300001
M	078300002
L	078300003
XL	078300004
XXL	078300005
XXXL	078300006



"STRONG" Work trousers

7816G

Work trousers, multipocket style

- T/C canvas, 65% polyester, 35% cotton, 260 g reinforced in polyester 600D
- Higher waist in rear part for increased back protection
- Waist key ring
- Large side pockets with press-stud closure, one with badge insert
- Tearproof crotch



XS	078160000
S	078160001
M	078160002
L	078160003
XL	078160004
XXL	078160005
XXXL	078160006



7880SC

Stretch work trousers

- T/C canvas, 63% polyester, 34% cotton, 3% stretch fabric, 290 g
- Tearproof crotch
- Ruler pocket and hammer loop
- Knee pad inserts



XS	078800000
S	078800001
M	078800002
L	078800003
XL	078800004
XXL	078800005
XXXL	078800006



7900E

Work trousers, multipocket style

- T/C canvas, 65% polyester, 35% cotton, 260 g
- Hammer loop
- Triple stitching in points more subject to wear
- Metal zip closure
- Ruler pocket and hammer loop



XS	079000900
S	079000901
M	079000902
L	079000903
XL	079000904
XXL	079000905
XXXL	079000906
XXXXL	079000907



7525

Work jeans in stretch denim cotton

- 68% denim cotton, 29% polyester, 3% stretch fabric, 10 OZ
- Large left-hand pocket with snap button closure and small tool pocket
- Ruler pocket and hammer loop
- Tearproof crotch



XS	075250046
S	075250048
M	075250050
L	075250052
XL	075250054
XXL	075250056
XXXL	075250058



7634G

New item

Technical sweatshirt, long-zipped

- 67% polyester, 28% rayon, 5% spandex, 325 g
- 3D fabric for improved breathability and freedom of movement



XS	076340100
S	076340101
M	076340102
L	076340103
XL	076340104
XXL	076340105
XXXL	076340106

7683

Softshell jacket with detachable hood and sleeves

- 94% polyester, 6% spandex, 290 g
- Detachable hood with string adjusters
- Detachable sleeves
- Jacket with waterproof, windproof, breathable TPU membrane

S	076830001
M	076830002
L	076830003
XL	076830004
XXL	076830005
XXXL	076830006



7780T

Work bomber jacket, multipocket style

- Main fabric: 100% nylon 300D, waterproof, hard-wearing
- Inserts for ease of movement: 95% polyester 5% stretch fabric, waterproof
- Polyester padding, 160 g
- Detachable hood, padded, lined, with string adjusters

S	077800101
M	077800102
L	077800103
XL	077800104
XXL	077800105
XXXL	077800106

- **FRONT ZIP CLOSURE**
- **EXTERIOR CHEST POCKET WITH ZIP CLOSURE AND BADGE INSERT**
- **INTERIOR CHEST POCKET WITH VERTICAL ZIP CLOSURE**

- **TWO WAIST POCKETS WITH ZIP CLOSURE**
- **TWO INTERIOR WAIST POCKETS**
- **STRETCH WAIST TAPE FOR IMPROVED FIT**



NEW LINE 100% STRETCH COTTON

7930G

Work trousers

- 100% stretch cotton, 220 g
- Slim fit

New item



XS	079300300
S	079300301
M	079300302
L	079300303
XL	079300304
XXL	079300305
XXXL	079300306

7933G

Work overalls

- 100% stretch cotton, 220 g
- Slim fit

New item



XS	079330300
S	079330301
M	079330302
L	079330303
XL	079330304
XXL	079330305
XXXL	079330306

7935G

Work overalls

- 100% stretch cotton, 220 g
- Slim fit

New item



XS	079350300
S	079350301
M	079350302
L	079350303
XL	079350304
XXL	079350305
XXXL	079350306

7939G

Work jacket

- 100% stretch cotton, 220 g
- Slim fit

New item



XS	079390300
S	079390301
M	079390302
L	079390303
XL	079390304
XXL	079390305
XXXL	079390306

7931G

Work Bermuda shorts

- 100% stretch cotton, 220 g
- Slim fit

New item



XS	079310300
S	079310301
M	079310302
L	079310303
XL	079310304
XXL	079310305
XXXL	079310306



Work OVERALLS and JACKETS

7865E

Work overalls, lightweight

- T/C twill, 65% polyester, 35% cotton, 180 g

XS	078650900
S	078650901
M	078650902
L	078650903
XL	078650904
XXL	078650905
XXXL	078650906



7863E

Work overalls, lightweight

- T/C twill, 65% polyester, 35% cotton, 180 g

XS	078630900
S	078630901
M	078630902
L	078630903
XL	078630904
XXL	078630905
XXXL	078630906
XXXXL	078630907



7905E

Work overalls

- T/C canvas, 65% polyester, 35% cotton, 260 g

XS	079050900
S	079050901
M	079050902
L	079050903
XL	079050904
XXL	079050905
XXXL	079050906
XXXXL	079050907



7903E

Work overalls

- T/C canvas, 65% polyester, 35% cotton, 260 g

XS	079030900
S	079030901
M	079030902
L	079030903
XL	079030904
XXL	079030905
XXXL	079030906
XXXXL	079030907



7869E

Work jacket, lightweight

- T/C twill, 65% polyester, 35% cotton, 180 g

XS	078690900
S	078690901
M	078690902
L	078690903
XL	078690904
XXL	078690905
XXXL	078690906
XXXXL	078690907



7867E

Sleeveless work jacket, multipocket style, lightweight

- T/C twill, 65% polyester, 35% cotton, 180 g

XS	078670900
S	078670901
M	078670902
L	078670903
XL	078670904
XXL	078670905
XXXL	078670906
XXXXL	078670907



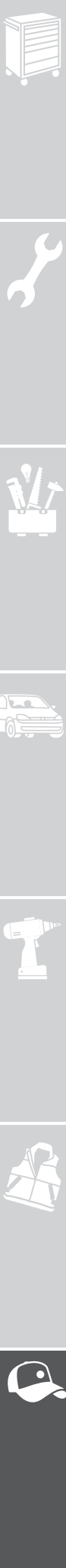

9563P

Office armchair, black



095630010

95740

Work gloves

- stretch-elastic cuffs
- reinforced thumbs and index fingers,
- made from touchscreen capable synthetic leather

M	095740202
L	095740203
XL	095740204
XXL	095740205



9525TL

Top Line cap



095250010

9548KB

Balance bike, aluminium frame, 12" wheel with inner tube; recommended for children from 3 years; maximum weight: 30 kg



095480110

9501TL

Sweatshirt,

- made of cotton (80%) and polyester (20%), 320 g

S	095010051
M	095010052
L	095010053
XL	095010054
XXL	095010055



9580S

Sunglasses "Summer" style



095800100

50 Years in Motorsports



Technical Partner





The images are for reference only. Beta Utensili S.p.A. reserves the right to update and upgrade its product range without notice.



Beta Utensili S.p.A. | via Volta, 18 | 20845 Sovico (MB) | ph. +39 039 20771
www.beta-tools.com